

3 Shape and space 1

In this unit you will:

- revise plotting coordinates
- revise drawing, estimating and constructing angles and shapes
- learn about the properties of shapes, including congruency and symmetry
- revise area and perimeter
- learn to draw shapes as scale drawings and isometric drawings.

Functional skills coverage and range:

- Recognise and use 2D representations of 3D objects
- Find area and perimeter of common shapes.

Links

Architects have to put their 3D designs onto paper using complex technical software that maps out plan, side and front views for them. Finding the area and perimeter of a shape is important for design work in graphics, garden design and construction.

3.1 Coordinates

3.1.1 x- and y-coordinates

- To get to the point P on this grid you go **across** 1 and **up** 3 from the bottom corner.

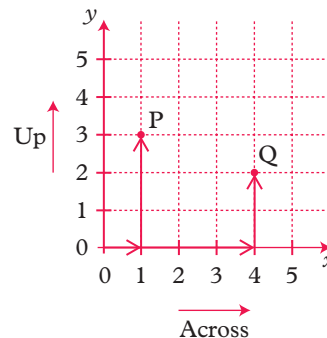

The position of P is (1, 3).

The numbers 1 and 3 are called the **coordinates** of P.

The coordinates of Q are (4, 2).

The **origin** is at (0, 0).

Notice also that the **lines** are numbered, **not** the squares.

- The first coordinate is the x-coordinate and the second coordinate is the y-coordinate.

- The **across** coordinate is always **first** and the **up** coordinate is **second**.

Remember: 'Along the corridor and up the stairs'.

Exercise 1

- 1 Write the coordinates of all the points A to K like this: A(5, 1) B(1, 4)
Don't forget the brackets.

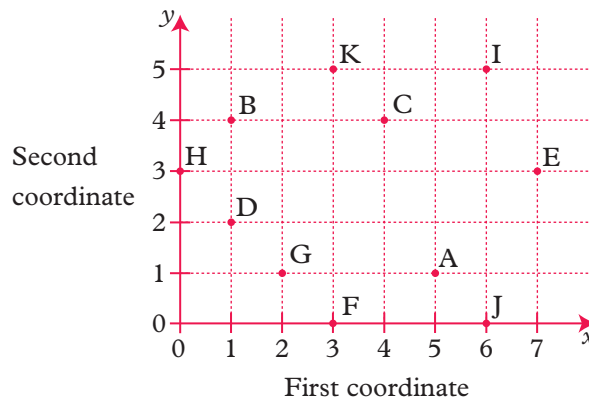

- 2 Write the coordinates of the points which make up the '2' and the 'S' in the diagram. You must give the points in the correct order.

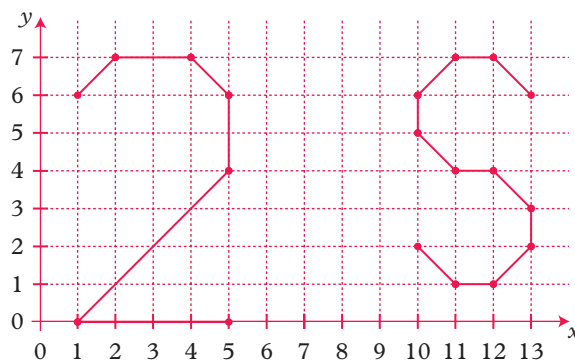

In questions 3 to 6 plot the points and join them up in order.
You will get a picture in each case.

- 3 Draw x - and y -axes from 0 to 10.

A: (3, 2), (4, 2), (5, 3), (3, 5), (3, 6), (2, 7), (1, 6), (1, 8),
(2, 9), (3, 9), (5, 7), (4, 6), (4, 5), (6, 4), (8, 4), (8, 5),
(6, 7), (5, 7).

B: (7, 4), (9, 2), (8, 1), (7, 3), (5, 3).

C: (1, 6), (2, 8), (2, 9), (2, 7).

D: Draw a dot at (3, 8).

- 4 Draw x - and y -axes from 0 to 10.

A: (6, 5), (7, 6), (9, 5), (10, 3), (9, 1), (1, 1), (3, 3), (3, 4),
(4, 5), (5, 4), (4, 3), (6, 4), (8, 4), (9, 3).

B: (8, 3), (8, 2), (7, 1).

C: (6, 3), (6, 2), (5, 1).

D: (5, 2), (4, 1).

E: Draw a dot at (3, 2).

- 5 Draw x - and y -axes from 0 to 8.
 A: (6, 6), (1, 6), (2, 7), (7, 7), (6, 6), (6, 1), (7, 2), (7, 7).
 B: (1, 6), (1, 1), (6, 1).
 C: (3, 5), (3, 3), (2, 2), (2, 5), (5, 5), (5, 2), (2, 2), (3, 3), (5, 3).
- 6 Draw the x -axis from 0 to 8 and the y -axis from 0 to 4.
 A: (7, 1), (8, 1), (7, 2), (6, 2), (5, 3), (3, 3), (2, 2), (6, 2), (1, 2), (1, 1), (2, 1).
 B: (3, 1), (6, 1).
 C: (3, 3), (3, 2).
 D: (4, 3), (4, 2).
 E: (5, 3), (5, 2).
 F: Draw a circle of radius $\frac{1}{2}$ unit with centre at $(2\frac{1}{2}, 1)$.
 G: Draw a circle of radius $\frac{1}{2}$ unit with centre at $(6\frac{1}{2}, 1)$.
- 7 Use the grid to work out the joke written in coordinates.
 Work down each column.

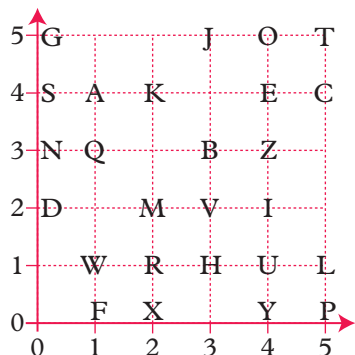

↓	(1, 1)	(4, 0)	(1, 4)	(1, 1)	(0, 4)	(0, 2)
	(3, 1)	(4, 5)		(4, 2)	(5, 0)	(4, 5)
	(1, 4)	(4, 1)	(2, 2)	(5, 5)	(1, 4)	(4, 1)
	(5, 5)		(1, 4)	(3, 1)	(0, 2)	(0, 5)
		(5, 4)	(0, 3)		(4, 4)	
	(0, 2)	(1, 4)		(1, 4)		
	(4, 5)	(5, 1)				
	(5, 1)					

Exercise 2 L

In this exercise some coordinates will have negative numbers.

- 1 Write the coordinates of all the points A to I like this:
 A(3, -2) B(4, 3).

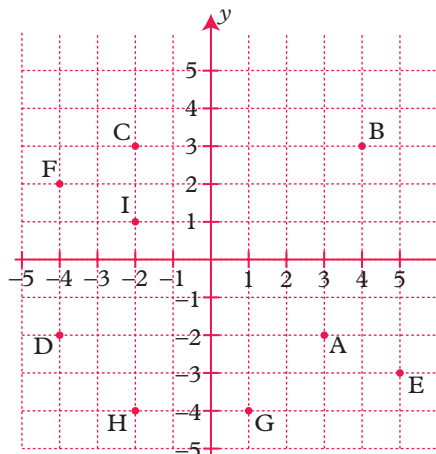

2 Plot the points and join them up in order.

You should produce a picture.

Draw axes with x from -4 to $+4$ and y from 0 to 10 .

A: $(3, 5), (2, 7), (0, 8), (-1, 8), (-2, 7),$
 $(-3, 7), (-4, 8), (-2, 9), (0, 9), (2, 8), (3, 7),$
 $(3, 2), (1, 1), (0, 3), (-2, 2), (-2, 4), (-3, 4),$
 $(-2, 6), (-1, 6), (-1, 5), (-2, 6), (-2, 7).$

B: $(-1, 3), (-2, 3).$

C: $(1, 3), (0, 3).$

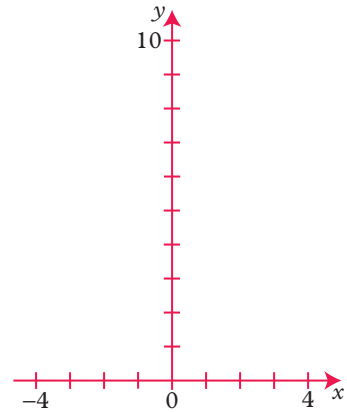

3 The graph shows several incomplete quadrilaterals. Copy the diagram and complete the shapes.

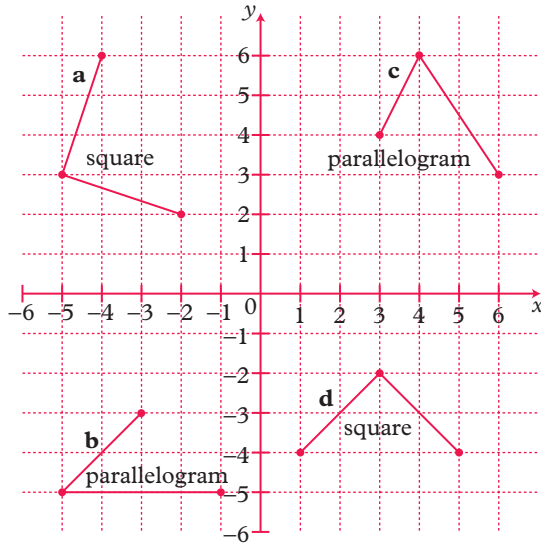

- Write the coordinates of the fourth vertex of each shape.
- Write the coordinates of the centre of each shape.

A vertex is a corner of a shape.

4 Copy this graph.

- A, B and C are three corners of a square. Write the coordinates of the other corner.
- C, A and D are three corners of another square. Write the coordinates of the other corner.
- B, D and E are three corners of a rectangle. Write the coordinates of the other corner.
- C, F and G are three vertices of a parallelogram. Write the coordinates of the other vertex.

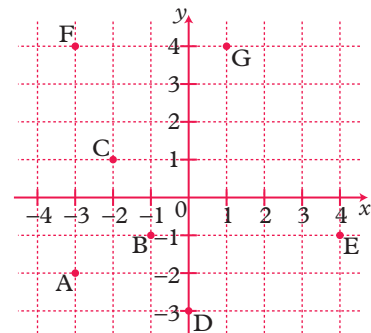

- A 'straight line' has infinite length. It goes on for ever!
- A 'line segment' has finite length.

For example the line segment PQ has end points P and Q.

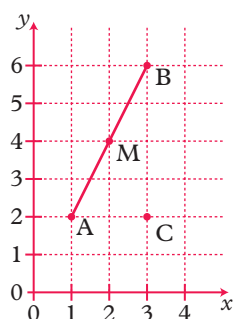

The diagram shows the line segment AB joining A(1, 2) and B(3, 6).

You find the coordinates of the midpoint, M, by adding the x - and y -coordinates of A and B and then dividing by 2.

So M is the point $\left(\frac{1+3}{2}, \frac{2+6}{2}\right)$.

M has coordinates (2, 4).

You can find the **length** of the line segment AB using Pythagoras' Theorem (section 7·8).

$$\begin{aligned} AB^2 &= BC^2 + AC^2 \\ AB^2 &= 4^2 + 2^2 \\ AB &= \sqrt{20} \end{aligned}$$

- *5** Find the coordinates of the midpoint of the line joining C(2, 5) and D(6, 7).
- *6** Use the method in question 5 to find the midpoints of these line segments.
- A(2, 1) and B(8, 3)
 - C(1, 3) and D(5, 0)
 - E(2, 3) and F(10, 7)
 - G(0, 8) and H(4, 2)
 - I(2, -2) and J(6, 4)
 - K(4, -3) and L(0, 7)

- *7** Find the length of line segments:



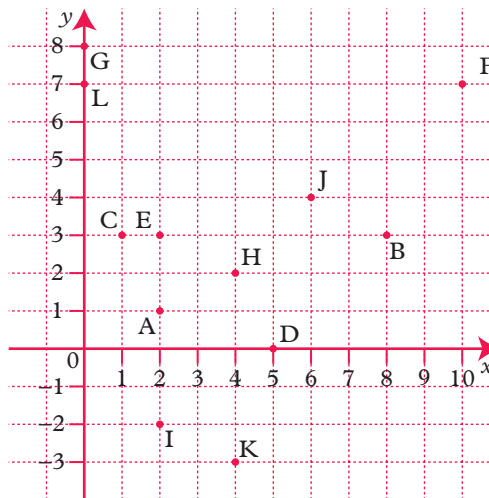

- JF
- EJ



3.2 Using angles

3.2.1 Estimating angles

- Angles are measured in **degrees**.

- Any angle between 0° and 90° is called an **acute** angle.  acute
- Any angle between 90° and 180° is called an **obtuse** angle.  obtuse
- Any angle bigger than 180° is called a **reflex** angle.  reflex
- An angle of 90° is called a **right angle**. There is a special symbol for a right angle.  right angle symbol

When the angle between two lines is 90° you say the lines are **perpendicular**. 

A full turn = 360°
 A half turn = 180°
 A quarter turn = 90°

Exercise 3 L

Write whether these angles are correctly or incorrectly labelled. Do **not** measure the angles – estimate! Where the angles are clearly incorrect, write an estimate for the correct angle.

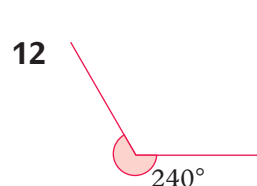
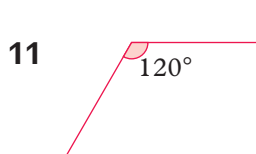
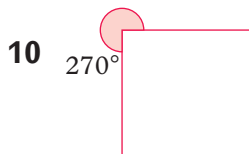
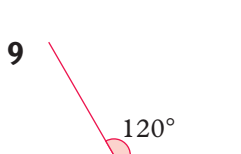
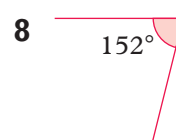
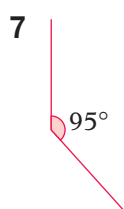
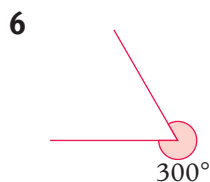
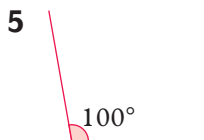
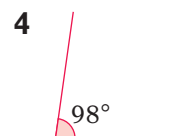
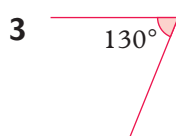
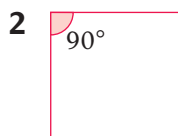
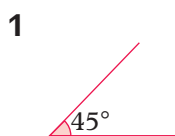

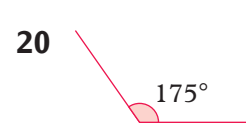
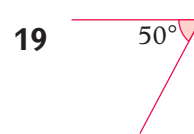
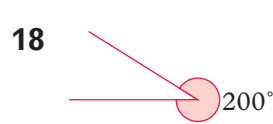
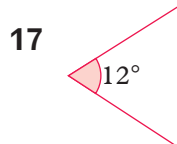
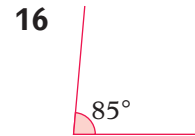
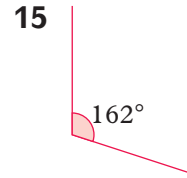
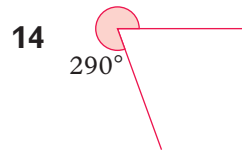
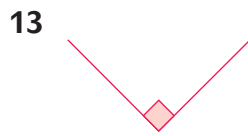

Exercise 4

For each angle in Exercise 3, write whether the angle **marked** is acute, obtuse, reflex or a right angle.

3.2.2 Angle facts

- The angles at a point add up to 360° .
- The angles on a straight line add up to 180° .
- Opposite angles at a vertex are equal.

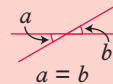
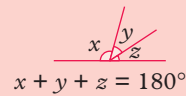
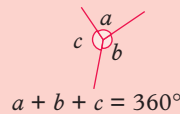

EXAMPLE

Find the angles marked with letters.

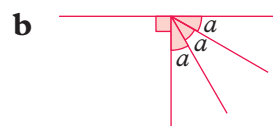
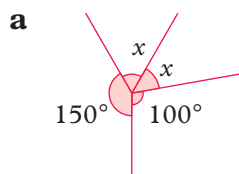

a $x + x + 150^\circ + 100^\circ = 360^\circ$

$$2x + 250^\circ = 360^\circ$$

$$2x = 360^\circ - 250^\circ$$

$$x = 55^\circ$$

b $3a + 90^\circ = 180^\circ$

$$3a = 90^\circ$$

$$a = 30^\circ$$

Exercise 5 M

Find the angles marked with letters. The line segments AB and CD in the diagrams from question 9 onwards are straight.

1

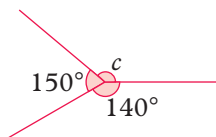

2

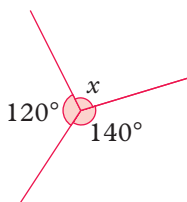

3

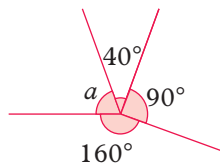

4

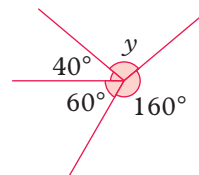

5

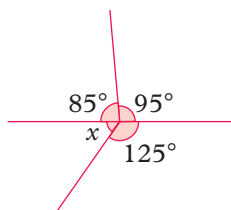

6

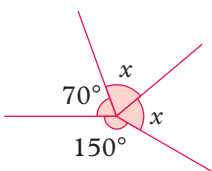

7

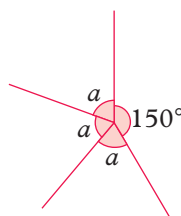

8

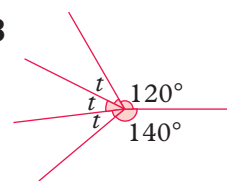

9

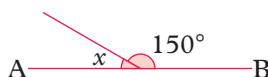

10

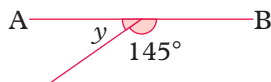

11

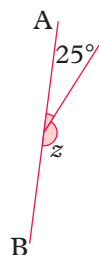

12

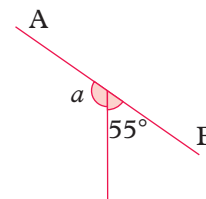

13

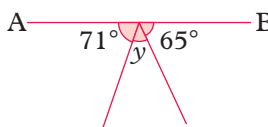

14

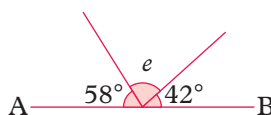

15

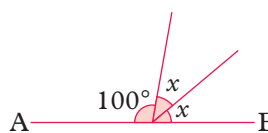

16

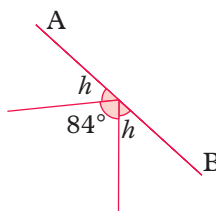

17

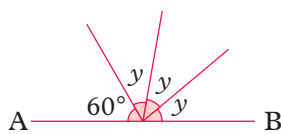

18

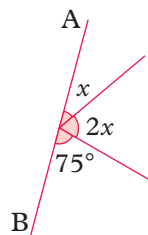

19

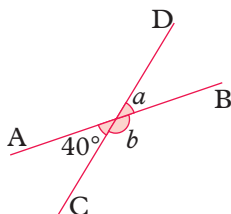

20

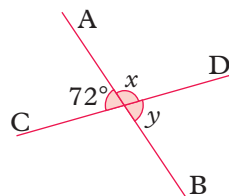

3.2.3 Angles in a triangle

Draw a triangle of any shape on a piece of card and cut it out accurately. Now tear off the three corners as shown.

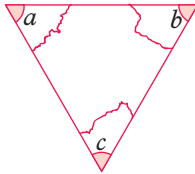

When the angles a , b and c are placed together they form a straight line.

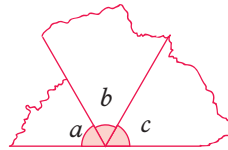

This is a **demonstration** that the angles add up to 180° . It is not a mathematical **proof**. A proof of this result is on page 116.

- The angles in a triangle add up to 180° .

Isosceles and equilateral triangles

An **isosceles** triangle has two equal sides and two equal angles. It has a line of symmetry down the middle.

The sides AB and AC are equal (marked with a dash) and angles B and C are also equal.

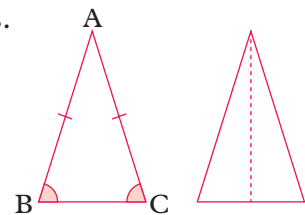

An **equilateral** triangle has three equal sides and three equal angles (all 60°).

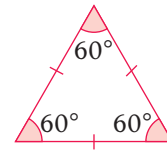

Find the angles marked with letters.

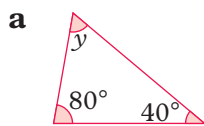

$$\begin{aligned} \mathbf{a} \quad y + 80^\circ + 40^\circ &= 180^\circ \\ y + 120^\circ &= 180^\circ \\ y &= 60^\circ \end{aligned}$$

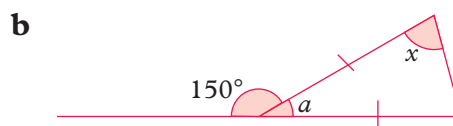

$$\begin{aligned} \mathbf{b} \quad a &= 180^\circ - 150^\circ = 30^\circ \\ \text{The triangle is isosceles, so} \quad 2x + 30^\circ &= 180^\circ \\ 2x &= 150^\circ \\ x &= 75^\circ \end{aligned}$$

Exercise 6 (M) / (L)

Find the angles marked with letters. For the more difficult questions it is helpful to draw a diagram.

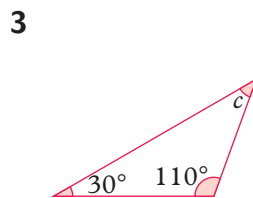
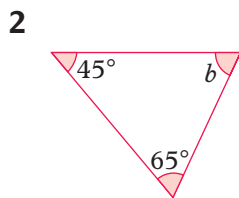
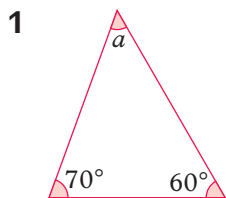

1 is a scalene triangle as all the angles are different.

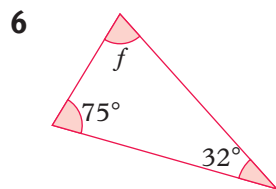
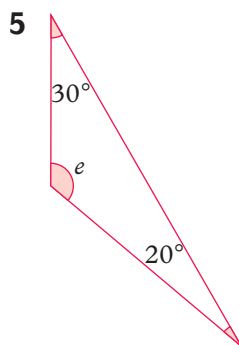
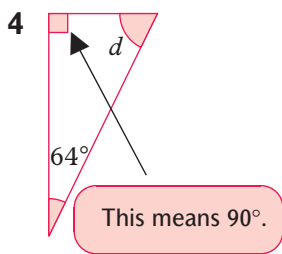

4 is a right-angled triangle because it contains a right angle.

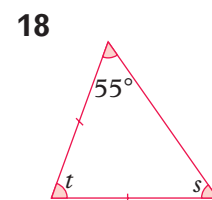
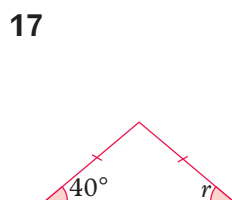
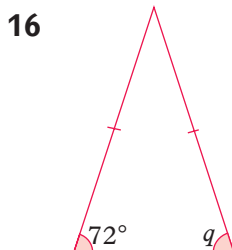
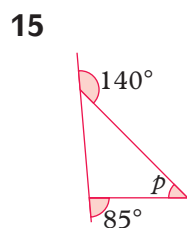
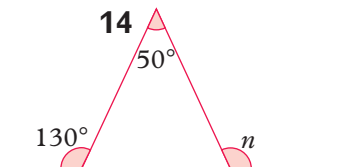
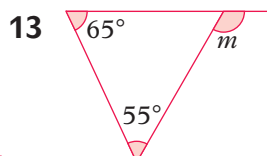
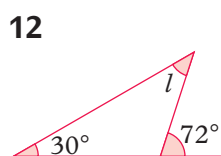
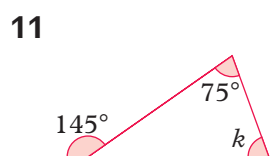
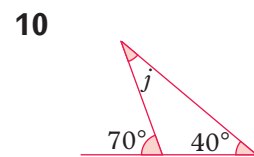
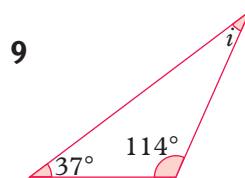
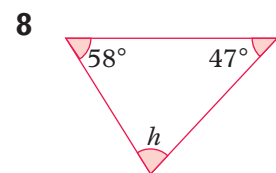

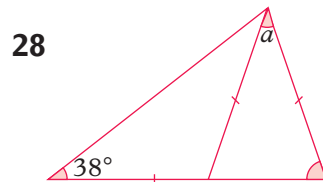
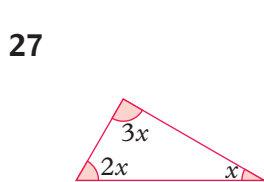
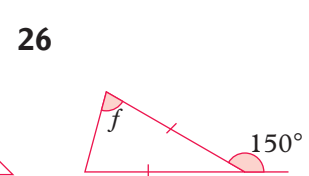
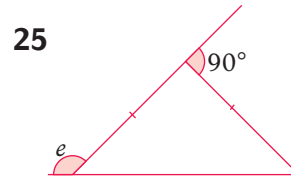
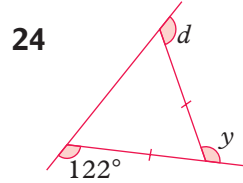
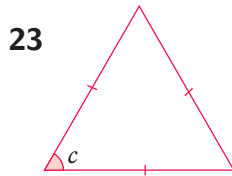
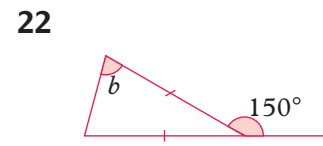
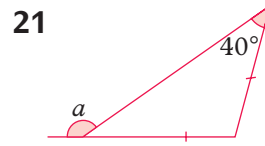
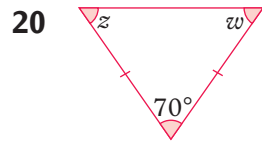
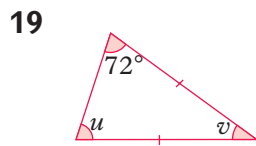

3.2.4 Parallel lines

- Parallel lines are always the same distance apart. They never meet.
- When a line cuts a pair of parallel lines all the acute angles are equal and all the obtuse angles are equal.

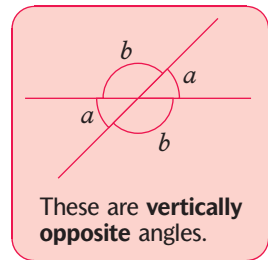

EXAMPLE

Some people remember:
 'F angles' and 'Z angles'

These are called **corresponding** angles. These are called **alternate** angles.

Exercise 7 (M)

Find the angles marked with letters.

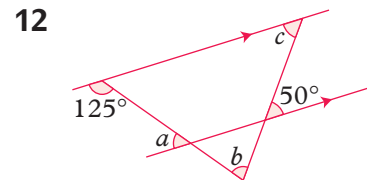
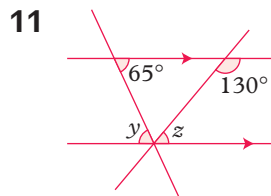
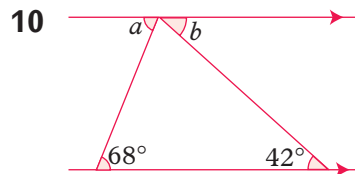
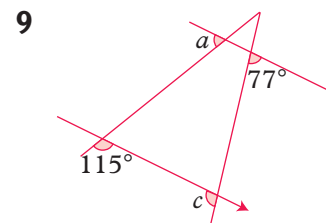
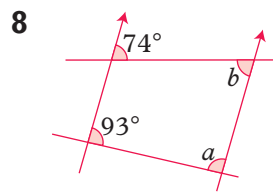
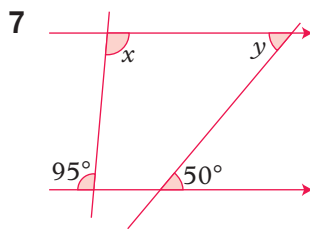
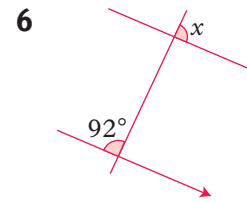
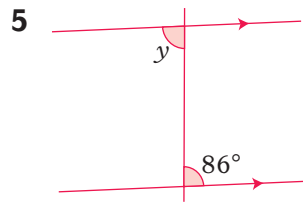
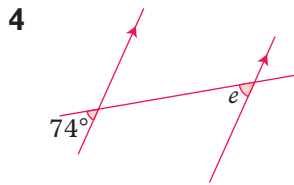
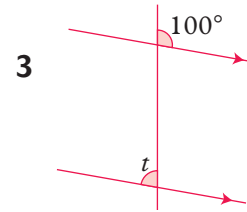
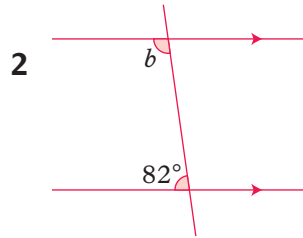
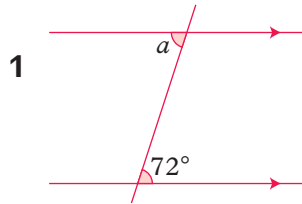

Exercise 8 (M)

The next exercise contains questions that use all the angle facts you have learnt.

Find the angles marked with letters.

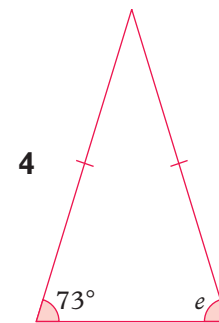
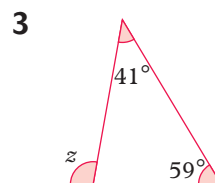
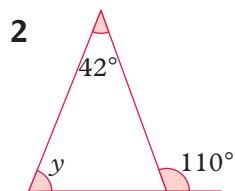
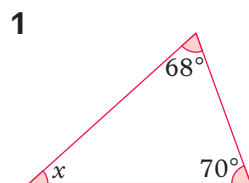

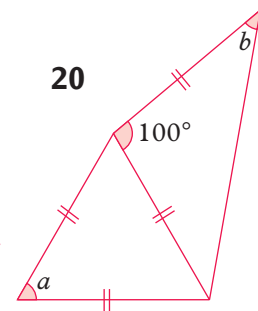
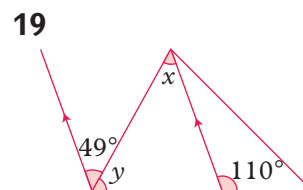
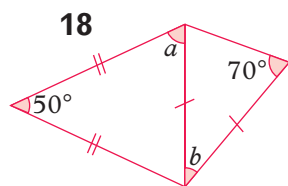
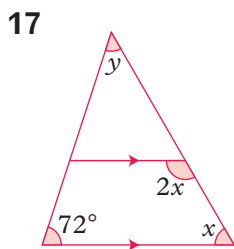
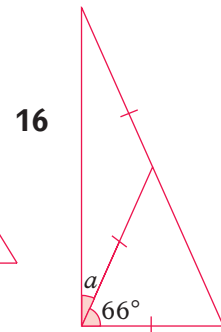
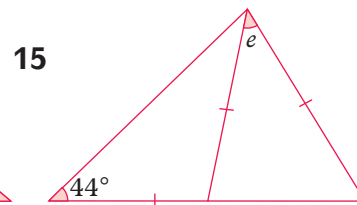
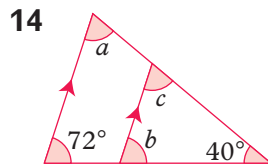
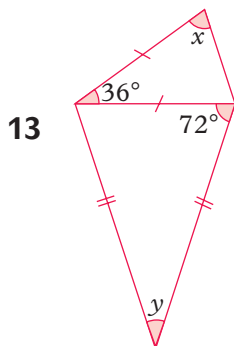
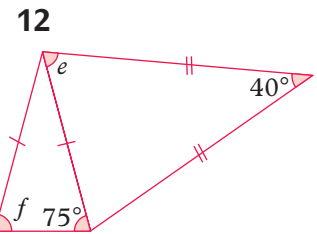
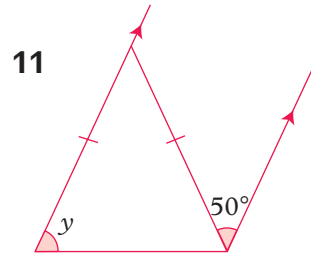
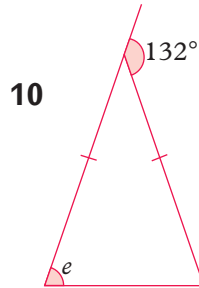
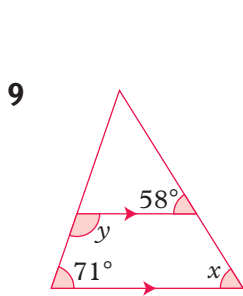
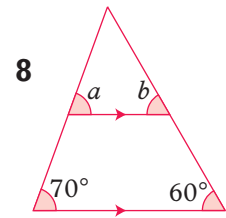
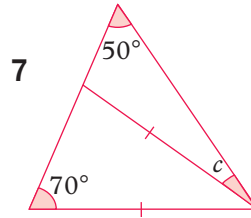
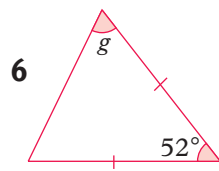
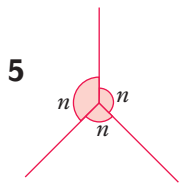

*21 The diagram shows two equal squares joined to a triangle. Find the angle x .

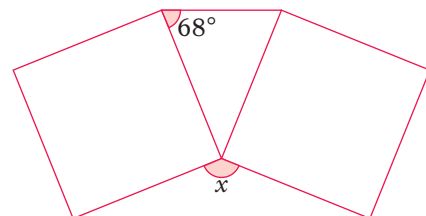

- *22 Find the angle a between the diagonals of the parallelogram.

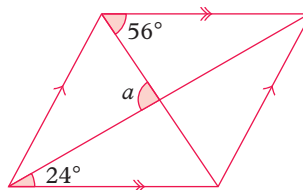

3.2.5 Proving results

On page 111, you **demonstrated** that the sum of the angles in a triangle is 180° , by cutting out the angles and rearranging them. A demonstration like this might not work for every possible triangle. When you **prove** results it means that the result is true for every possible shape. You can often prove one simple result and then use that result to prove further results.

- Here is a proof that the sum of the angles in a triangle is 180° .

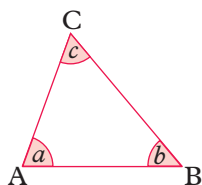

Here is $\triangle ABC$.

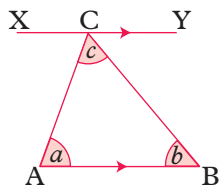

Draw line XCY parallel to AB.

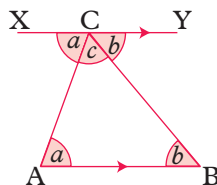

$\angle ABC = \angle YCB$ (alternate angles)
 $\angle BAC = \angle ACX$ (alternate angles)
 $a + b + c = 180^\circ$ (angles on a straight line)

So, angles in a triangle: $a + b + c = 180^\circ$

\triangle is a symbol that means triangle.

This proves that the sum of the angles in a triangle is 180° .

Exercise 9 M

Teacher's note: Proof is not an easy topic for most students. Some teachers may choose to go through these proofs on the board so that students can copy them down. It is desirable that students should have an **understanding** of the proof rather than the ability to reproduce it (which is not required in examinations).

- 1 Copy and complete this proof that the sum of the angles in a quadrilateral is 360° .

Draw any quadrilateral ABCD with diagonal BD.

Now $a + b + c = \square$ (angles in a \triangle)

and $d + e + f = \square$ (angles in a \triangle)

So, $a + b + c + d + e + f = \square$

This proves the result.

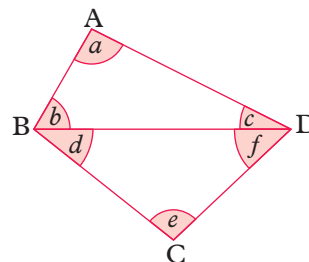

- 2 The exterior angle of a triangle is equal to the sum of the two interior opposite angles.

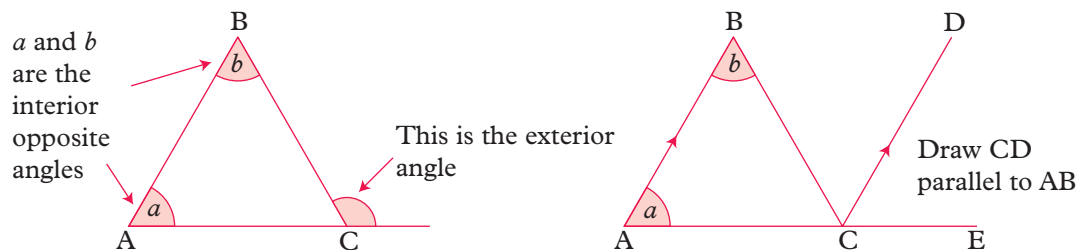

Copy and complete this proof:

$$\angle BAC = \angle DCE \text{ (corresponding angles) ('F' angles)}$$

$$\angle ABC = \angle \square \text{ (alternate angles) ('Z' angles)}$$

$$\text{So, } \square = \square + \square$$

- 3 Prove that opposite angles of a parallelogram are equal. (Use alternate and corresponding angles.)

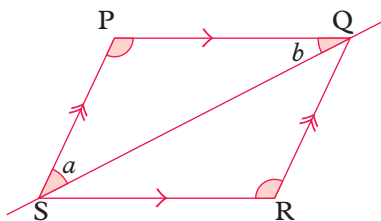

3.3 Accurate drawing

3.3.1 Using a protractor and a pair of compasses

Some questions involving bearings or irregular shapes are easy to solve if you draw an accurate diagram.

To improve the accuracy of your work, follow these guidelines.

- Use a **sharp** HB pencil.
- Don't press too hard.
- If you are drawing an **acute** angle make sure your angle is less than 90° .
- If you use a pair of compasses make sure they are fairly stiff so the radius does not change accidentally.

Using a protractor

You use a protractor to measure angles accurately.

Remember: When you measure an **acute** angle the answer must be less than 90° . When you measure an **obtuse** angle the answer must be more than 90° .

Exercise 10 (L)

Measure these angles.

1

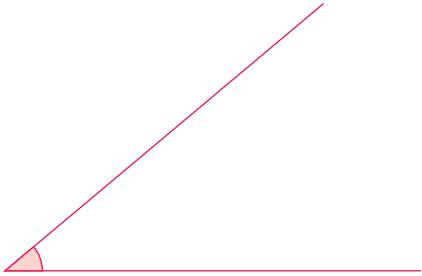

2

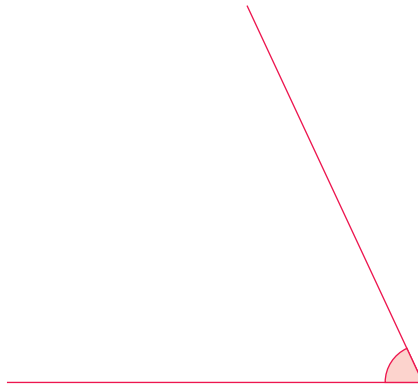

3

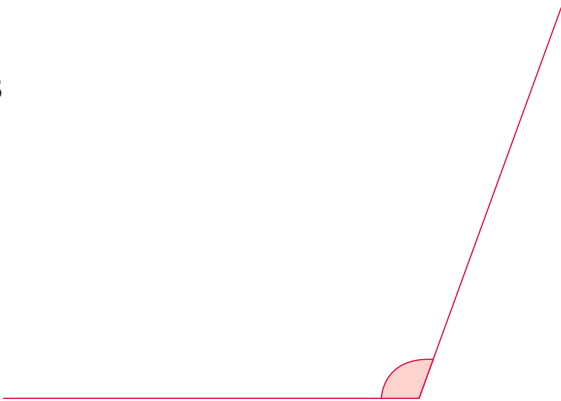

4

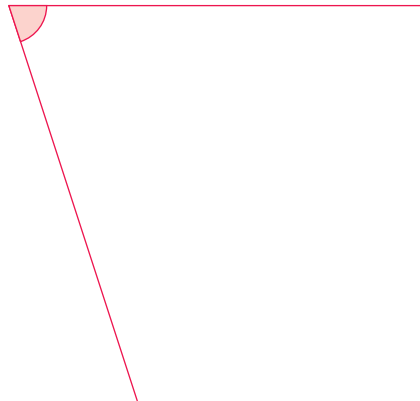

In questions 5, 6, 7 and 8 measure all the angles and all the sides in each triangle.

5

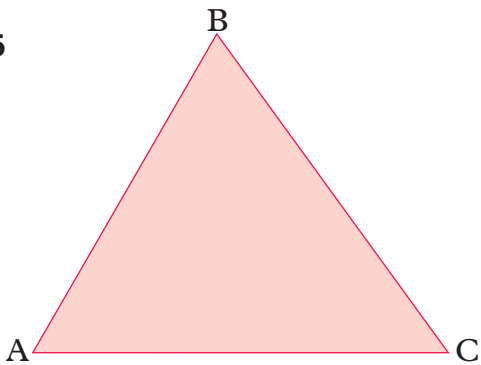

6

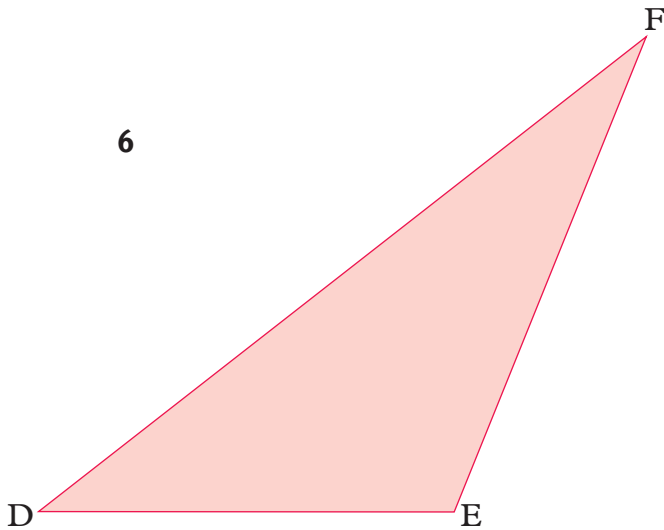

7

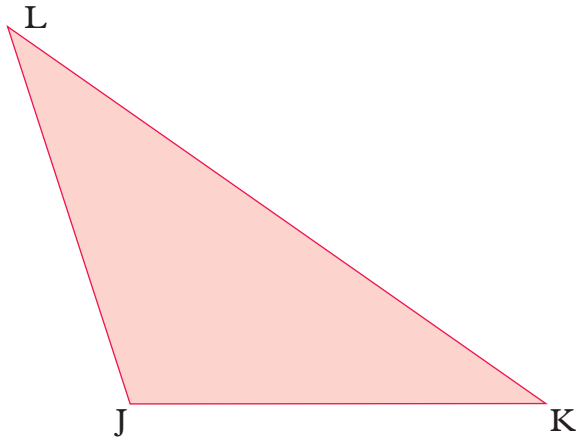

8 G

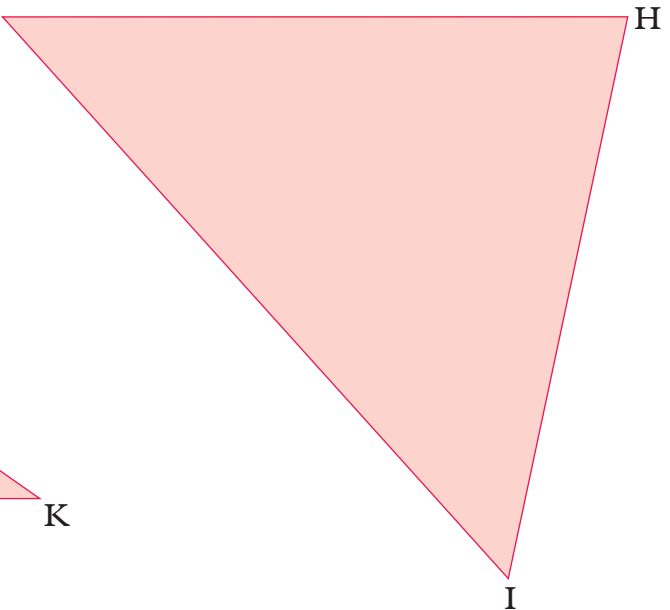

9 Draw these angles **accurately**.

- a 40° b 62° c 110° d 35° e 99° f 122°

3.3.2 Constructing triangles

EXAMPLE

Draw the triangle ABC full size and measure the length x .

- a Draw a base line **longer than 8.5 cm**.
 b Put the centre of the protractor on A and measure an angle of 64° . Draw line AP.
 c Similarly draw line BQ at an angle of 40° to AB.
 d You have drawn the triangle!
 Measure $x = 5.6$ cm

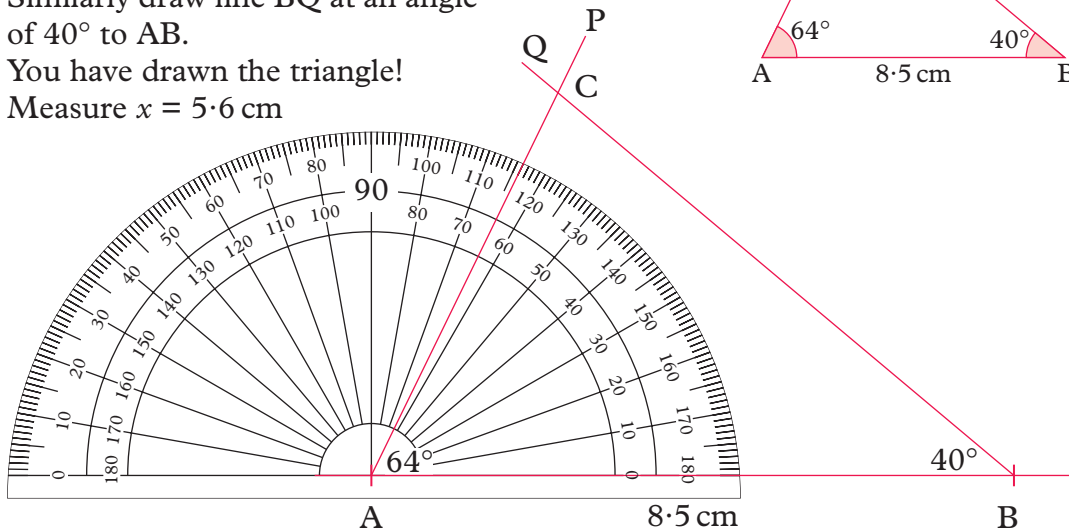
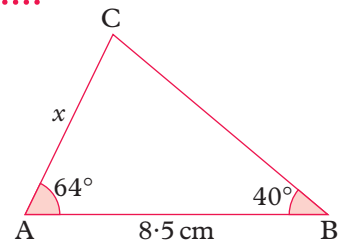

Exercise 11 (M)

Use a protractor and ruler to draw full size diagrams and measure the sides marked with letters.

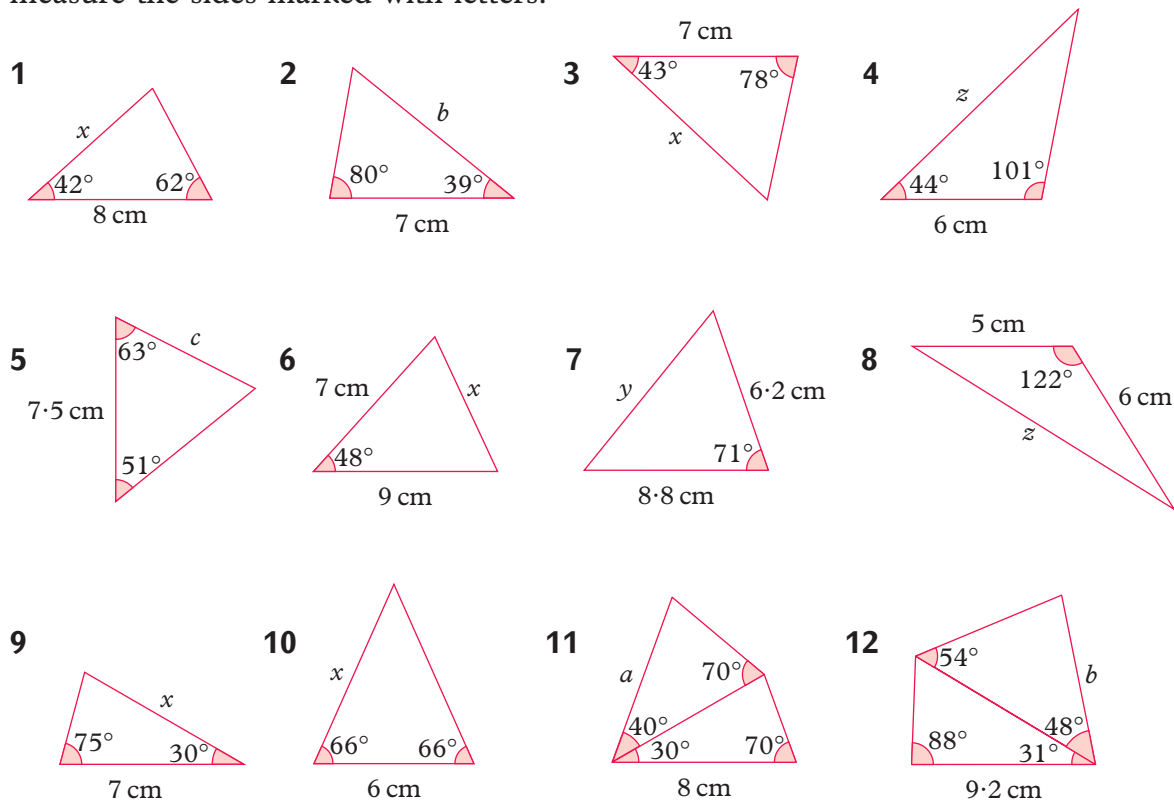

Exercise 12 (M)

This exercise will show you how to draw a triangle, if you have three sides.

- 1 Follow these steps to draw a triangle with sides 7 cm, 5 cm, 6 cm.

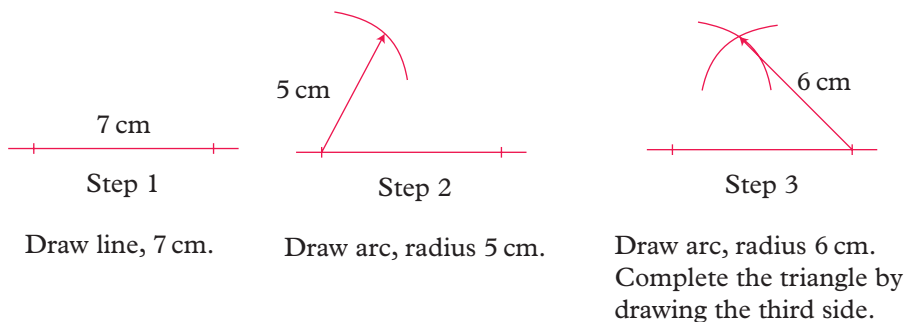

- 2 a Construct an equilateral triangle with sides of 6 cm.
b Construct an equilateral triangle with sides of 7.5 cm.

In questions 3 to 6 construct the triangles using a pair of compasses.

Measure the angles marked with letters.

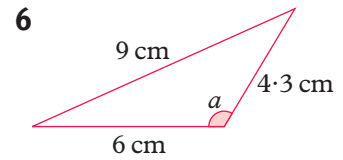
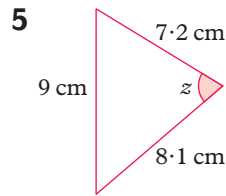
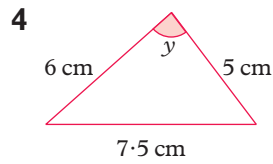
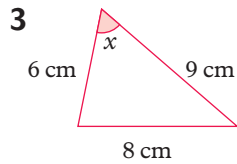

Constructing unique triangles

You can describe a triangle according to the information you have.

You use: S when you know a side,
A when you know an angle,
R when you know there is a right angle,
H when you know the hypotenuse of a right-angled triangle.

- Here are five examples.

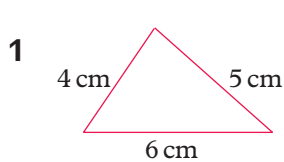

SSS

All 3 sides

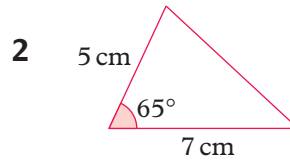

SAS

2 sides and the included angle

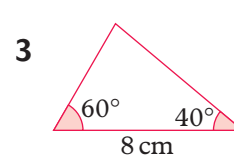

ASA

2 angles and one side

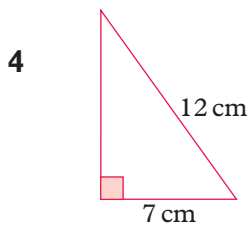

RHS

Right angle, hypotenuse and side

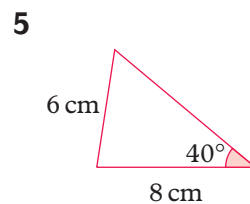

SSA

2 sides and an angle (not included)

Exercise 13 (M)/(H)

- Using a ruler, protractor and a pair of compasses construct each of the triangles 1, 2, 3 and 4. Label the triangles SSS, SAS, ASA, RHS.

2 Construct triangle 5 and, using a pair of compasses, show that it is possible to construct two different triangles with the sides and angle given.

3 Construct the triangle in the diagram.

You are given SSA.

Show that you can construct two different triangles with the sides and angle given.

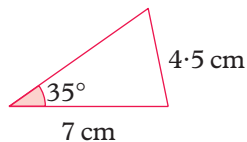

4 Copy and complete these two sentences.

‘When you know SSS, SAS, or the constructed triangle is unique.

When you know the triangle is not unique and it is sometimes possible to construct two different triangles.’

These are the conditions for triangles to be congruent (see page 126).

3.3.3 Nets

If the cube here was made of cardboard, and you cut along some of the edges and laid it out flat, you would have the **net** of the cube.

A cube has: 8 vertices (corners)
6 faces
12 edges.

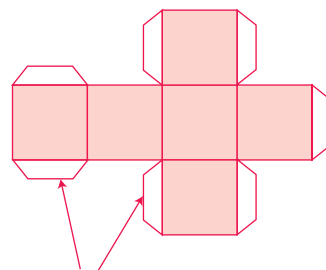
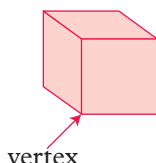

Here is the net for a square-based pyramid.

This pyramid has: 5 vertices
5 faces
8 edges.

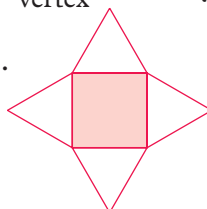

Exercise 14 M

You will need pencil, ruler, scissors and either glue or sticky tape.

1 Which of these nets could you use to make a cube?

a

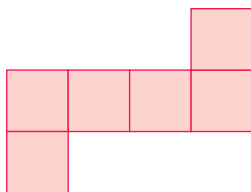

b

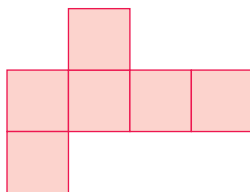

c

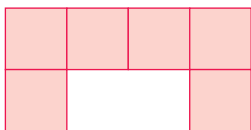

d

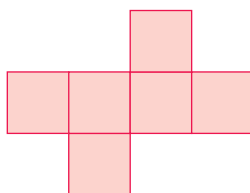

If you want to create a 3-D shape you need to add tabs to your net to glue your shape together.

- 2 The numbers on opposite faces of a dice add up to 7. Take one of the possible nets for a cube from question 1 and show the number of dots on each face.

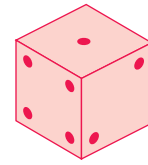

- 3 Here is the start of the net of a cuboid (a closed rectangular box) measuring $4\text{ cm} \times 3\text{ cm} \times 1\text{ cm}$. Copy and then complete the net.

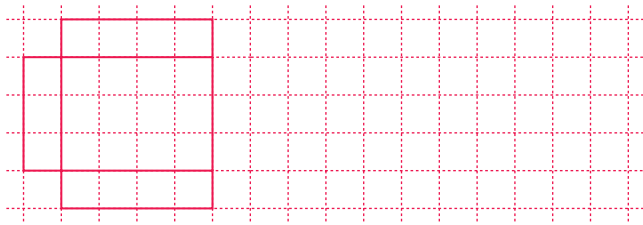
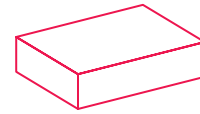

- 4 This diagram needs one more square to complete the net of a cube. Draw the **four** possible nets which would make a cube.

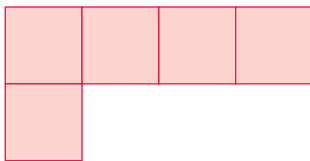

- *5 You can make a solid from each of these nets.

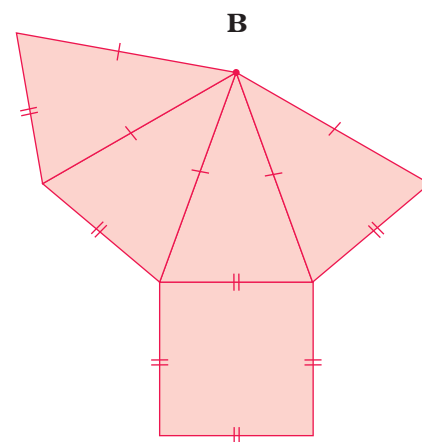
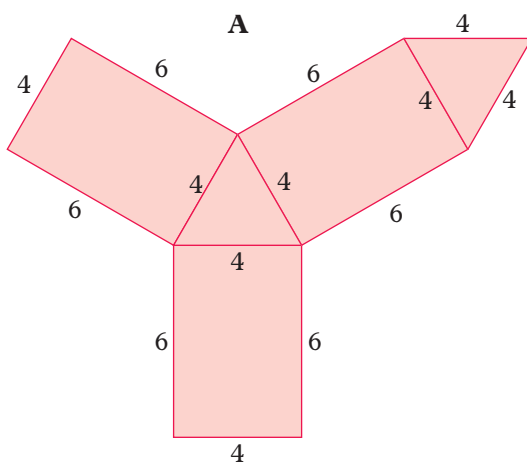

- a State the number of vertices and faces for each solid.
 b One object is a square-based pyramid and the other is a triangular-based prism. Which one is which?

- 6 Some interesting objects can be made using triangle dotted paper. The basic shape for the nets is an equilateral triangle. With the paper as shown the triangles are easy to draw.

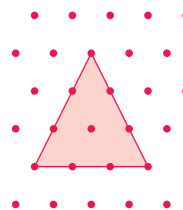

Make the sides of the triangles 3 cm long so that the solids are easy to make. Here is the net of a regular tetrahedron. Draw it and then cut it out.

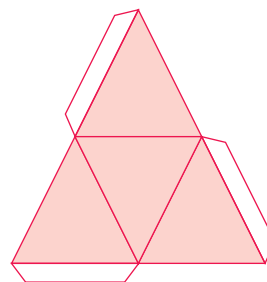

3.3.4 Constructions with a ruler and compasses

1 Perpendicular bisector of a line segment AB

With centres A and B draw two arcs with your compass. Keep the same radius. Join the points where the arcs intersect (the broken line).

An arc is a section of a circle.

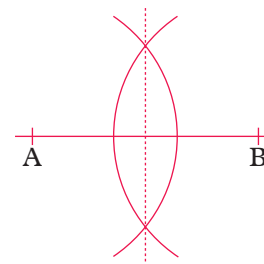

This line is the perpendicular bisector of AB.

2 Perpendicular from point P to a line

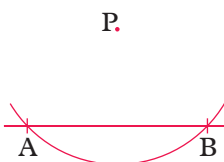
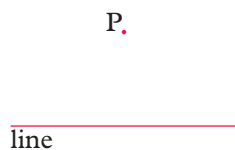

With centre P draw an arc to cut the line at A and B.

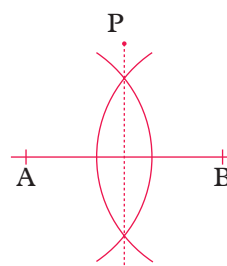

Construct the perpendicular bisector of AB. Use a smaller radius on your compasses.

3 Bisector of an angle

With centre A draw arc PQ.
 With centres at P and Q draw two more arcs.
 Keep the same radius.
 Join the point of intersection of the two arcs to A.
 This line is the bisector of angle A.

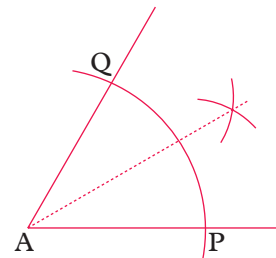

Exercise 15 (M)

Use only plain unlined paper, a pencil, a straight edge and a pair of compasses.

- 1 Draw a line AB of length 6 cm. Construct the perpendicular bisector of AB.
- 2 Draw a line CD of length 8 cm. Construct the perpendicular bisector of CD.
- 3 Draw a line and a point P about 4 cm from the line. Construct the line which passes through P and is perpendicular to the line.
- 4 **a** Using a set square, draw a right-angled triangle ABC as shown. For greater accuracy draw lines slightly longer than 8 cm and 6 cm and **then** mark the points A, B and C.
b **Construct** the perpendicular bisector of AB.
c Construct the perpendicular bisector of AC.
d If you do it accurately, your two lines from **b** and **c** should cross exactly on the line BC.

A straight edge is a ruler with no markings on it.

See Construction 2 on page 124.

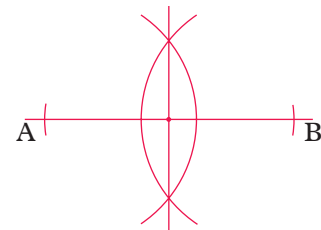
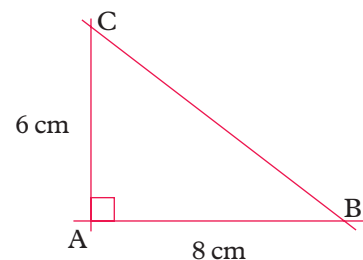

- 5 This is the construction of a perpendicular from a point P on a line, using ruler and compasses.
 - a** With centre P, draw arcs to cut the line at A and B.
 - b** Now construct the perpendicular bisector of AB. (Use a larger radius, and join the points where the arcs meet.)
- 6 Draw an angle of about 60° . Construct the bisector of the angle.
- 7 Draw an angle of about 80° . Construct the bisector of the angle.

? *8 Investigation

Draw any triangle ABC and then construct the bisectors of angles A, B and C. If you do it accurately the three bisectors should all pass through one point.

If they do **not** pass through one point (or very nearly) do this question again with a new triangle ABC.

Does this work with every type of triangle, for example scalene, isosceles?

See Construction 3 on page 125.

3.4 Congruent and similar shapes

3.4.1 What are congruent and similar shapes?

- **Congruent** shapes are exactly the same in shape and size. Shapes are congruent if one shape fits exactly over the other.

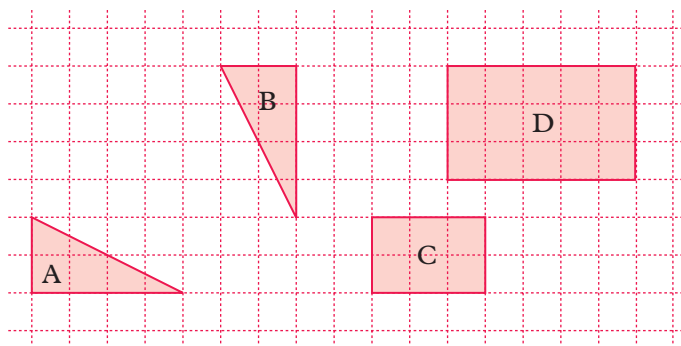

A and B are congruent

C and D are not congruent

- Shapes which are mathematically **similar** have the same shape, but different sizes. All **corresponding angles** in similar shapes are equal and **corresponding lengths** are in the same ratio.

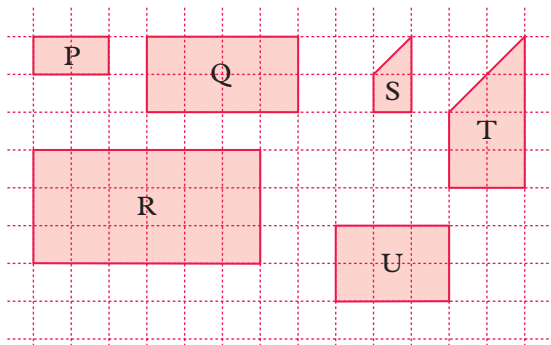

P, Q and R are similar. S and T are similar.

U is **not** similar to any of the shapes P, Q and R.

If two shapes are similar one shape is an **enlargement** of the other.

Note that all **circles** are similar to each other and all **squares** are similar to each other.

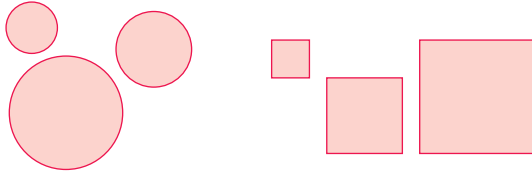

Exercise 16 (M)/(L)

1 Write the pairs of shapes that are congruent.

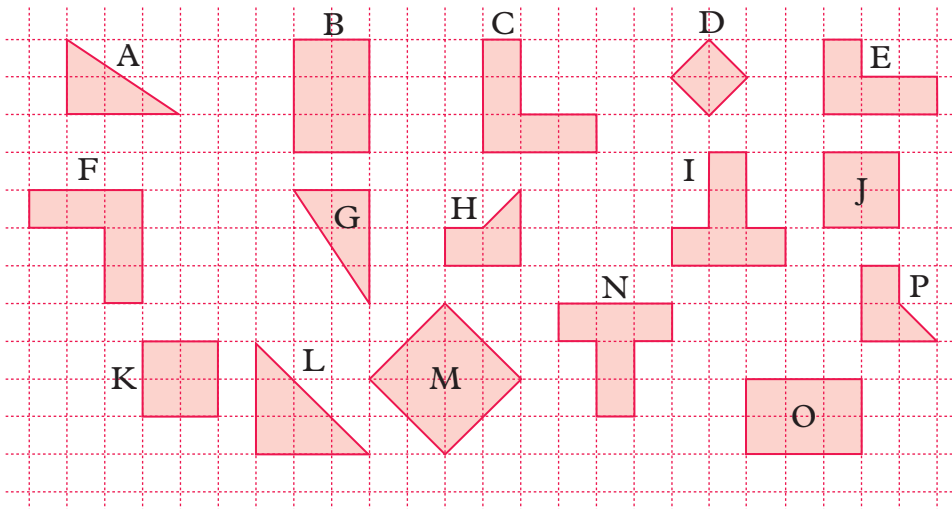

2 Copy the diagram onto squared paper and colour in the congruent shapes with the same colour.

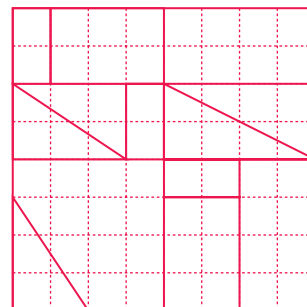

3 Copy shape X onto squared paper. Draw another shape which is congruent to shape X but turned into a different position.

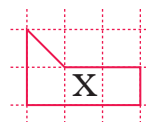

4 Make a list of pairs of shapes which are similar.

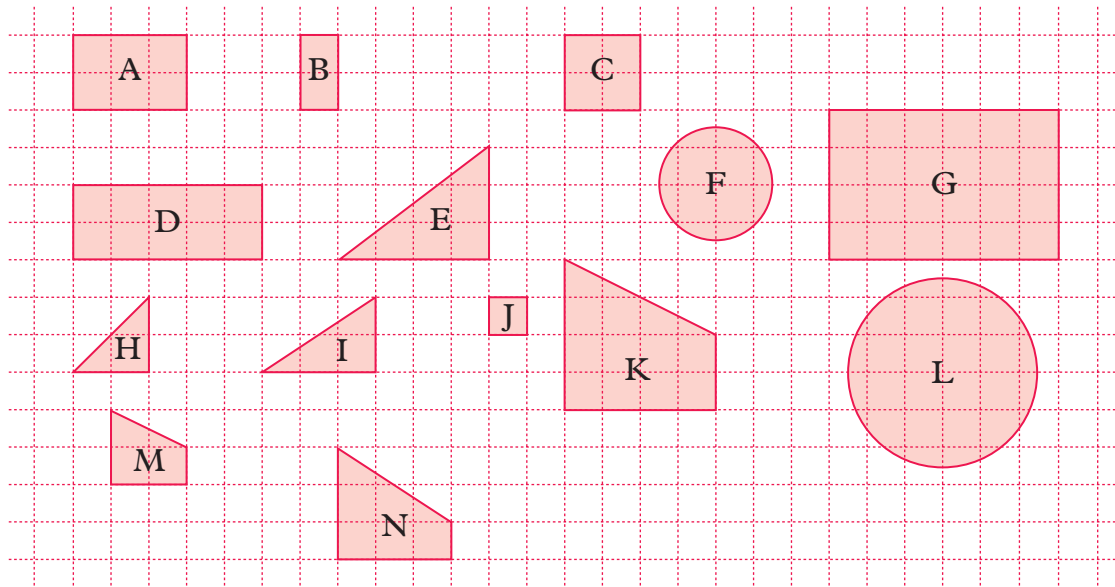

5 Draw shape I from question 4 on squared paper. Now draw a shape which is similar to shape I.

6 Here are two rectangles. Explain why they are not similar.

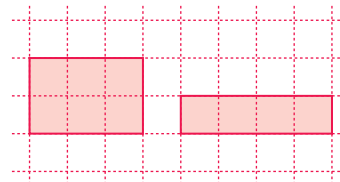

3.5 Tessellations

- A tessellation is formed when a shape (or shapes) fit together without gaps to cover a surface. Here are some examples.

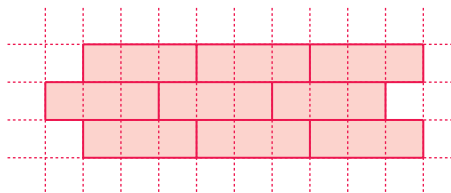
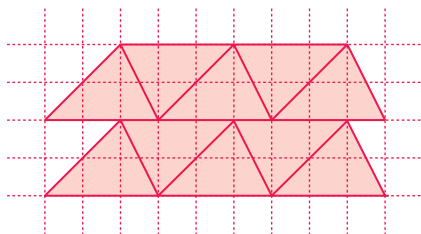

Exercise 17 (M)/(L)

- 1 Use squared paper to show that each of the shapes below tessellates.

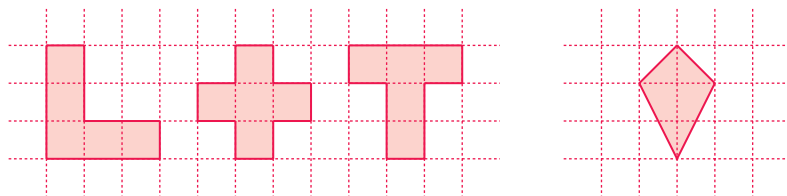

- 2 a Draw any irregular triangle or quadrilateral and cut twenty or so copies from cardboard or paper. Fit them together, like a jigsaw puzzle, to cover a plane.
 b Say whether the statements below are true or false:
 i 'all triangles tessellate'
 ii 'all quadrilaterals tessellate'.
- 3 Explain why regular hexagons tessellate and why regular pentagons do not.
- 4 Show, by drawing or otherwise, whether these combinations of polygons tessellate.
 a Regular octagons and squares.
 b Regular hexagons and triangles.

3.6 Symmetry**3.6.1 Line and rotational symmetry****Line symmetry**

The letter M has one line of symmetry, shown dotted.



A line of symmetry is like a mirror line.

Rotational symmetry

The shape may be turned about its centre into three identical positions. It has rotational symmetry of order **three**.

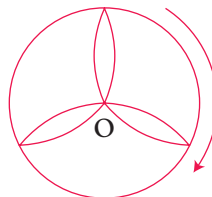

Exercise 18 (M) / (L)

For each shape write

- a the number of lines of symmetry
- b the order of rotational symmetry.

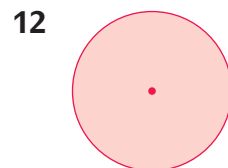
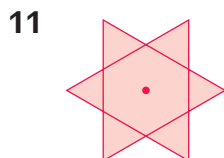
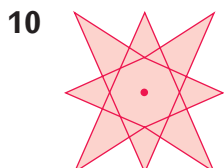
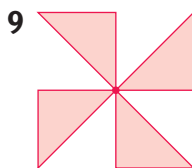
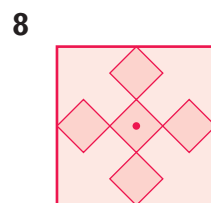
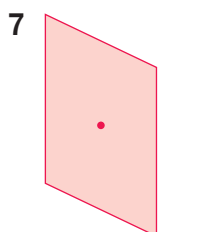
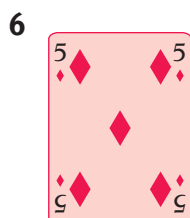
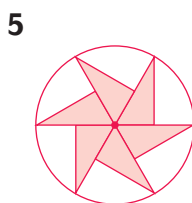
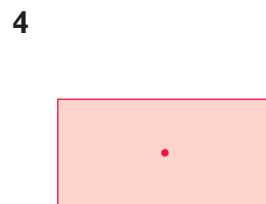
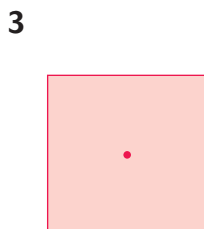
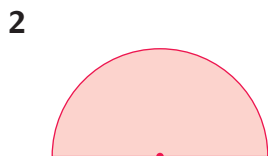
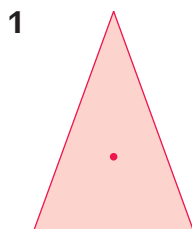

- 13** Here is a shape made using four squares.
- a Copy the shape and add one square so that the new shape has one line of symmetry. Do this in two different ways.
 - b Copy the shape again and add one square so that the new shape has rotational symmetry of order 2.

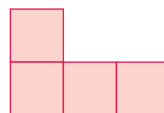

- 14**
- a Copy this shape and shade one more triangle so that the new shape has one line of symmetry.
 - b Copy the shape again and shade two more triangles so that the new shape has rotational symmetry of order 3.

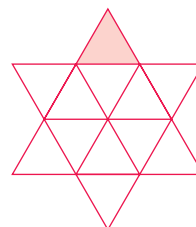

- 15** Look at this shape.
- a Copy the shape and add one square so that the shape has rotational symmetry of order 2.
 - b Copy the shape again and add one square so that the shape has one line of symmetry.

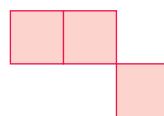

Exercise 19 

In questions 1 to 8, the broken lines are lines of symmetry.

In each diagram only **part of the shape** is given.

Copy the part shapes onto square grid paper and then carefully complete them.

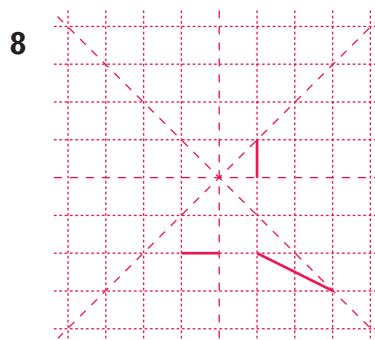
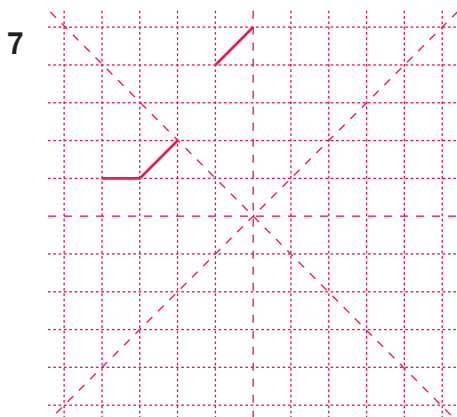
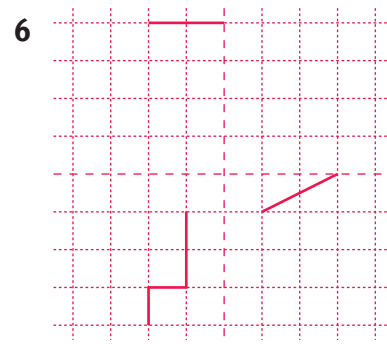
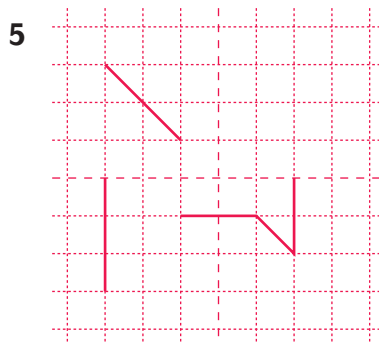
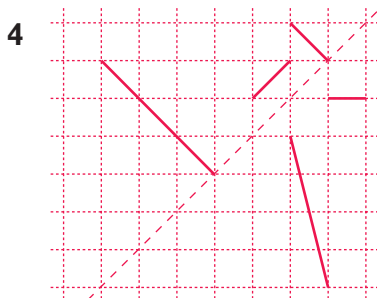
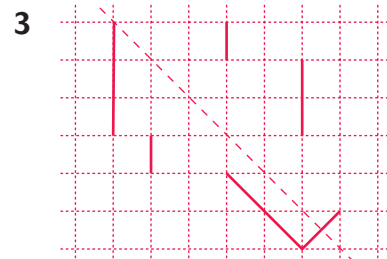
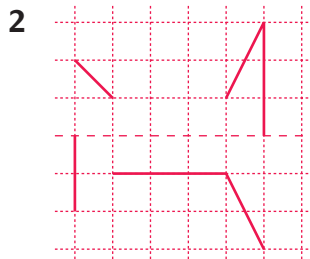
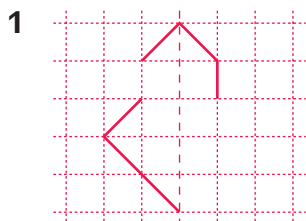

- 9 Fold a piece of paper twice and cut out any shape from the corner. Open the shape and stick it in your book stating the number of lines of symmetry and the order of rotational symmetry.

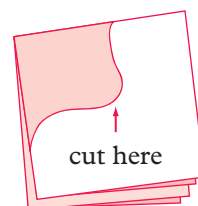

3.6.2 Planes of symmetry

- A **plane of symmetry** divides a 3-D shape into two congruent shapes. One shape must be a mirror image of the other shape.

The diagrams show two planes of symmetry of a cube.

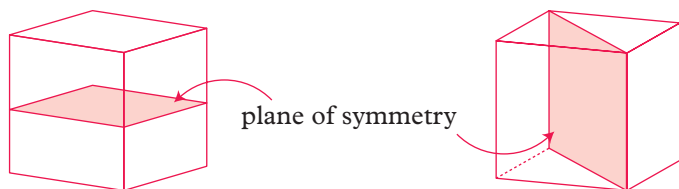

Exercise 20 M

- 1 How many planes of symmetry does this cuboid have?

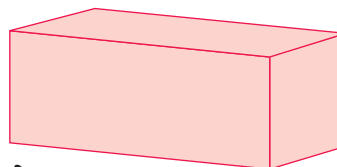

- 2 How many planes of symmetry do these shapes have?

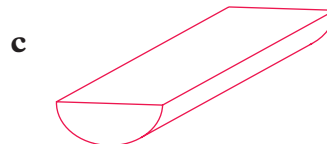
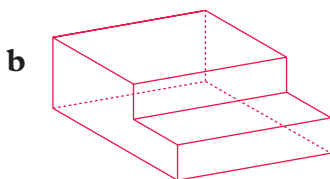
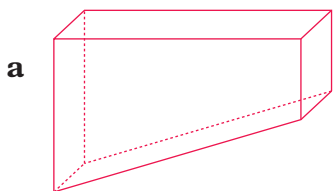

- 3 **a** Draw a diagram of a cube like the one at the top of this page and draw a different plane of symmetry.
b How many planes of symmetry does a cube have?
- 4 Draw a pyramid with a square base so that the point of the pyramid is vertically above the centre of the square base. Show any planes of symmetry by shading.

- 5 The diagrams show the plan view and the side view of an object.

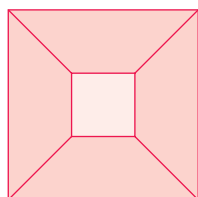

plan view

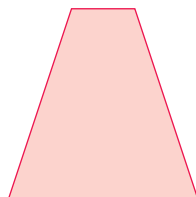

side view

The plan view is the view looking down on the object.

The side view is the view from one side.

How many planes of symmetry does this object have?

3.7 Quadrilaterals

3.7.1 Properties of quadrilaterals

- The angles in a quadrilateral always add up to 360° .

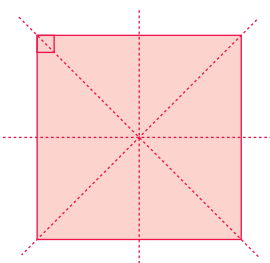
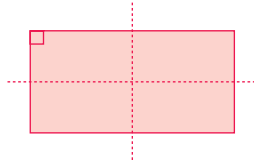
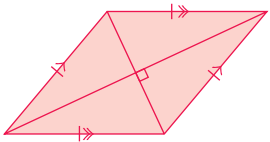
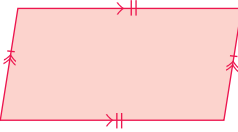
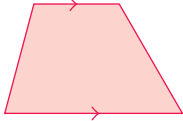
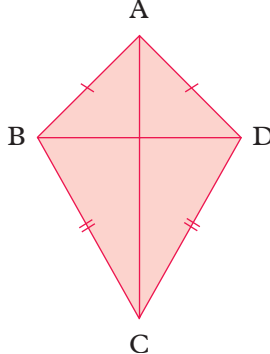
Title	Properties	
Square	Four equal sides All angles 90° Four lines of symmetry Rotational symmetry of order 4	
Rectangle (not square)	Two pairs of equal and parallel sides All angles 90° Two lines of symmetry Rotational symmetry of order 2	
Rhombus	Four equal sides Opposite sides parallel Diagonals bisect at right angles Diagonals bisect angles of rhombus Two lines of symmetry Rotational symmetry of order 4	
Parallelogram	Two pairs of equal and parallel sides Opposite angles equal No lines of symmetry Rotational symmetry of order 2	
Trapezium	One pair of parallel sides Rotational symmetry of order 1	
Kite	$AB = AD, CB = CD$ Diagonals meet at 90° One line of symmetry Rotational symmetry of order 1	

Exercise 21 (M) / (L)

1 Write the correct names for these five quadrilaterals.

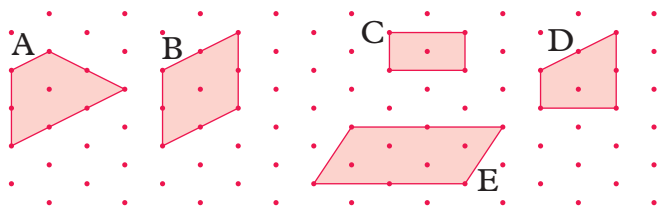

These are drawn on isometric paper.

2 Copy the table and fill all the boxes with either ticks or crosses.

	Diagonals always equal	Diagonals always perpendicular	Diagonals always bisect the angles	Diagonals always bisect each other
Square	✓			
Rectangle				
Parallelogram				
Rhombus				
Trapezium				

3 Find the angle x .

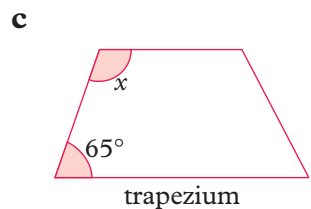
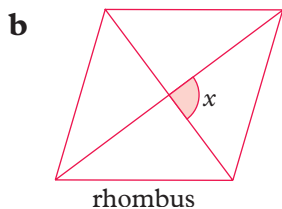
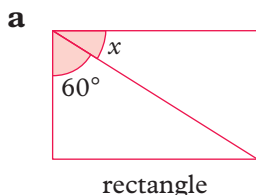

4 Copy each diagram onto square grid paper and mark the fourth vertex with a cross.

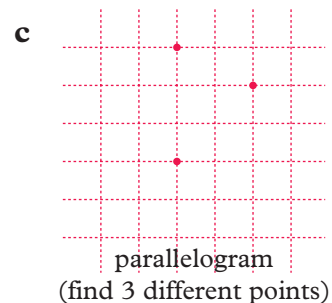
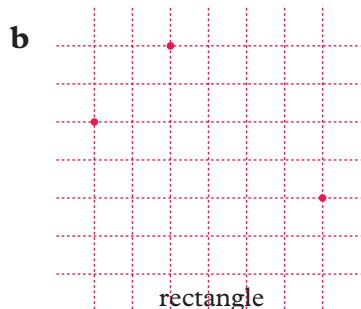
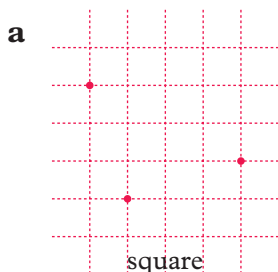

- 5 What is the name for all shapes with four sides?
- 6 What four-sided shape has all sides the same length and all angles equal?

- 7 What quadrilateral has two pairs of sides the same length and all angles equal?
- 8 Which quadrilateral has only one pair of parallel sides?
- 9 Name the triangle with three equal sides and angles.
- 10 What is the name of the triangle with two equal angles?
- 11 Which quadrilateral has all four sides the same length but only opposite angles equal?
- 12 True or false: 'All squares are rectangles.'
- 13 True or false: 'Any quadrilateral can be cut into two equal triangles.'

- 14 Name the shapes made by joining these points.

- a A B F G
- b C E F I
- c A B E H
- d A B D I

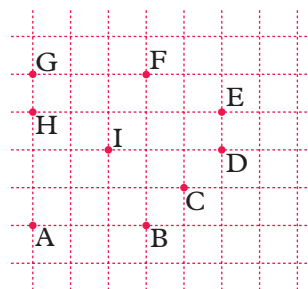

- 15 Name the shapes made by joining these points.

- a B I G E
- b A B E H
- c B C D F
- d C J G D
- e C J E

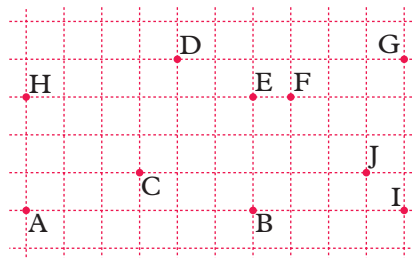

- 16 On square grid paper draw a quadrilateral with just two right angles and only one pair of parallel sides.

- *17 ABCD is a rhombus whose diagonals intersect at M. Find the coordinates of C and D, the other two vertices of the rhombus.

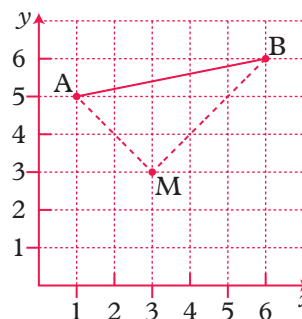

Exercise 22 

In these questions, begin by drawing a diagram and remember to put the letters around the shape in alphabetical order.

- 1 In a rectangle KLMN, $\angle LNM = 34^\circ$.

Calculate

- a $\angle KLN$
b $\angle KML$.

- 2 In a trapezium ABCD, $\angle ABD = 35^\circ$,
 $\angle BAD = 110^\circ$ and AB is parallel to DC.

Calculate

- a $\angle ADB$ b $\angle BDC$.

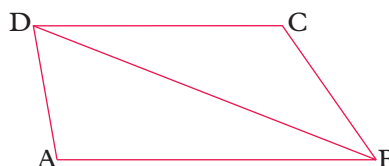

- 3 In a parallelogram WXYZ, $\angle WXY = 72^\circ$, $\angle ZWY = 80^\circ$.

Calculate

- a $\angle WZY$ b $\angle XWZ$ c $\angle WYX$.

- 4 In a kite ABCD, $AB = AD$, $BC = CD$, $\angle CAD = 40^\circ$ and
 $\angle CBD = 60^\circ$. Calculate

- a $\angle BAC$ b $\angle BCA$ c $\angle ADC$.

- 5 In a rhombus ABCD, $\angle ABC = 64^\circ$.

Calculate

- a $\angle BCD$
b $\angle ADB$
c $\angle BAC$.

- 6 In a rectangle WXYZ, M is the midpoint
of WX and $\angle ZMY = 70^\circ$. Calculate

- a $\angle MZY$ b $\angle YMX$.

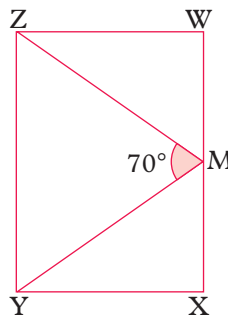

- 7 In a trapezium ABCD, AB is parallel to DC,
 $AB = AD$, $BD = DC$ and $\angle BAD = 128^\circ$.

Find

- a $\angle ABD$
b $\angle BDC$
c $\angle BCD$.

3.8 Isometric drawing

3.8.1 Drawing cuboids and solids made from cuboids

Here are two pictures of the same cuboid, measuring $4 \times 3 \times 2$ units.

When you draw a solid on paper you make a 2-D representation of a 3-D object.

1 On ordinary square paper

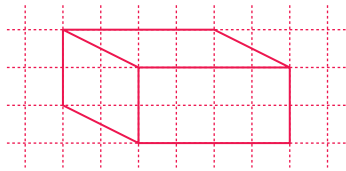

2 On isometric paper (a grid of equilateral triangles)

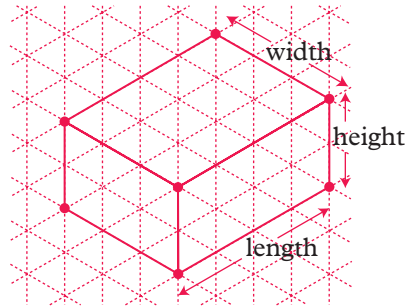

The dimensions of the cuboid cannot be taken from the first picture but they can be taken from the picture drawn on isometric paper. Instead of isometric paper you can also use 'triangular dotty' paper like this. Be careful to use it the right way round (as shown here).

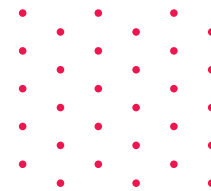

Exercise 23 M

In questions 1 to 3 the solids are made from 1cm cubes joined together. Draw each solid on isometric paper (or 'triangular dotty' paper). Questions 1 and 2 are already drawn on isometric paper.

1

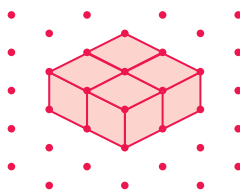

2

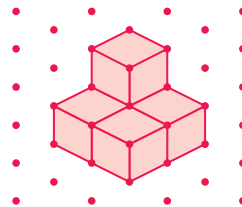

3

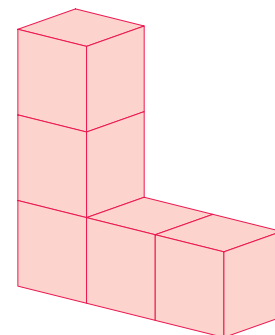

- 4 The diagram shows one edge of a cuboid.
Complete the drawings of **two** possible cuboids, each with a volume of 12 cm^3 . Start with this edge both times.

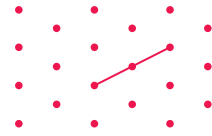

- 5 Here are two shapes made using four multilink cubes.

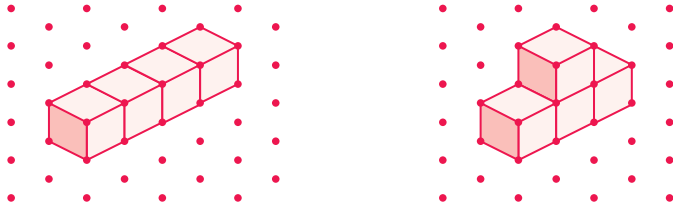

Using four cubes, make and then draw four more shapes that are different from the two above.

- 6 The shape shown falls over on to the shaded face.
Draw the shape after it has fallen over.

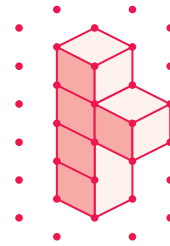

- ?** 7 You need 16 small cubes.
Make the two solids in the diagram and then arrange them into a $4 \times 4 \times 1$ cuboid by adding a third solid, which you have to find.
Draw the third solid on isometric paper.
There are **two** possible solids.

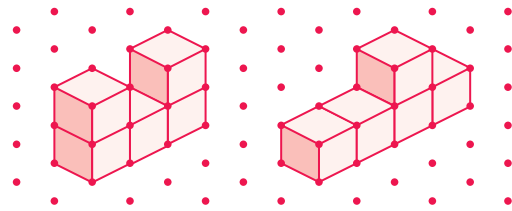

- 8 Make the letters of your initials from cubes and then draw them on isometric paper.
- 9 The side view and plan view (from above) of object A are shown.

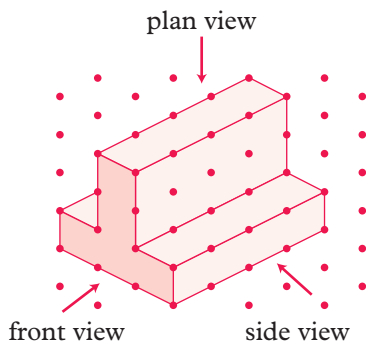

A

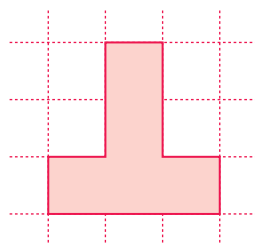

front view

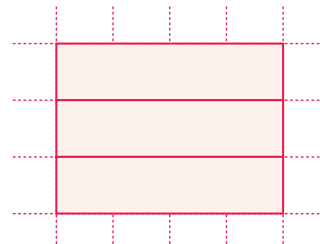

plan view

The side view is sometimes called the 'side elevation.'

Draw the side view and plan view of objects B and C.

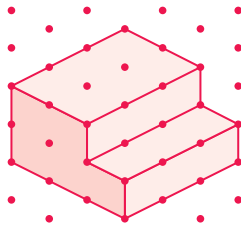

B

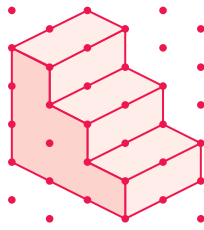

C

In questions 10 to 13 you are given three views of a shape. Use the information to make the shape using centimetre cubes and then draw a sketch of the solid.

10

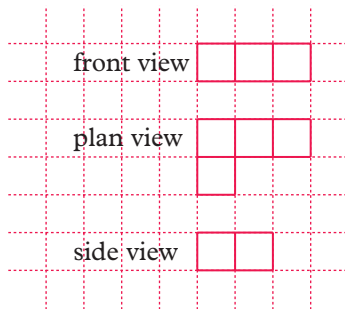

11

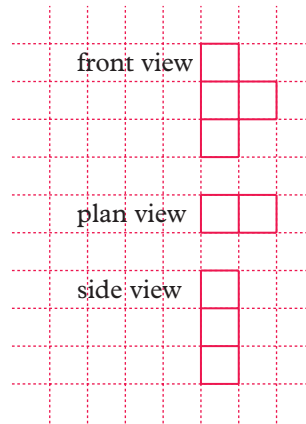

12

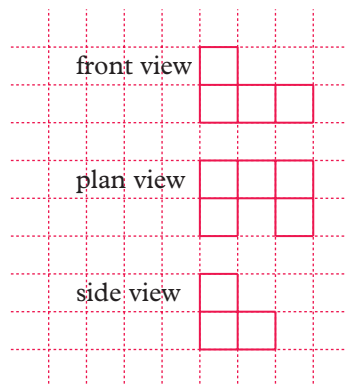

13

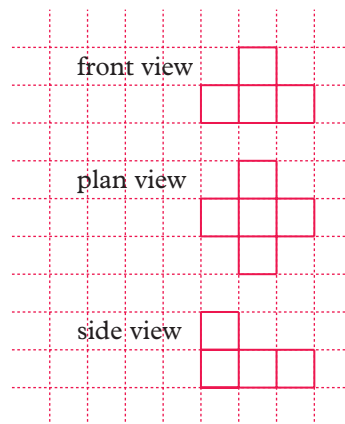

3.9 Area

3.9.1 Counting squares

- Area describes how much **surface** a shape has.

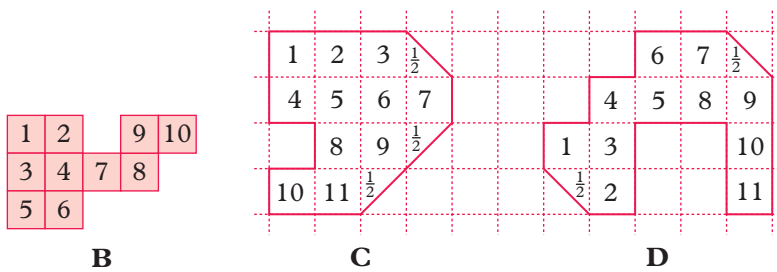

B contains 10 squares. C has an area of $12\frac{1}{2}$ squares.
 B has an area of 10 squares. D has an area of 12 squares.

- A square one centimetre by one centimetre has an area of one square centimetre. You write this as 1 cm^2 .

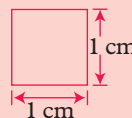

Exercise 24 L

In the diagrams each square represents 1 cm^2 .
 Copy each shape and find its area by counting squares.

1

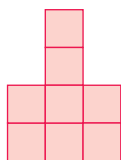

2

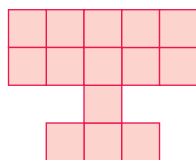

3

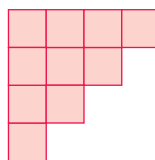

4

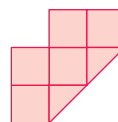

5

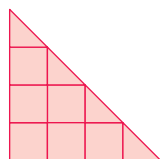

6

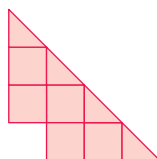

7

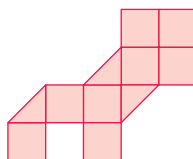

8

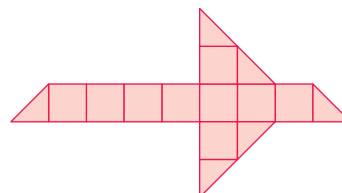

9 You can **estimate** the area of a curved shape like this.

a Count the whole squares inside the shape and mark them ✓.

b Count the parts where there is about half a square or more and mark them ✓.

c Ignore the parts where there is less than half a square inside the shape.

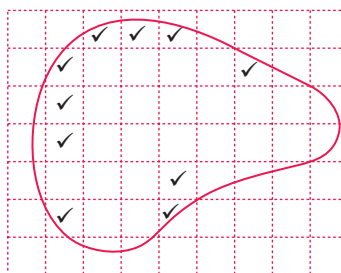

Each square represents 1 cm².

Some of the squares on the shape shown have been ticked according to the instructions **a**, **b** and **c**. Use a photocopy of this page to find an estimate for the area of the shape.

10 Use the method in question 9 to estimate the area of each of these shapes.
(Ask your teacher for a photocopy of this page.)

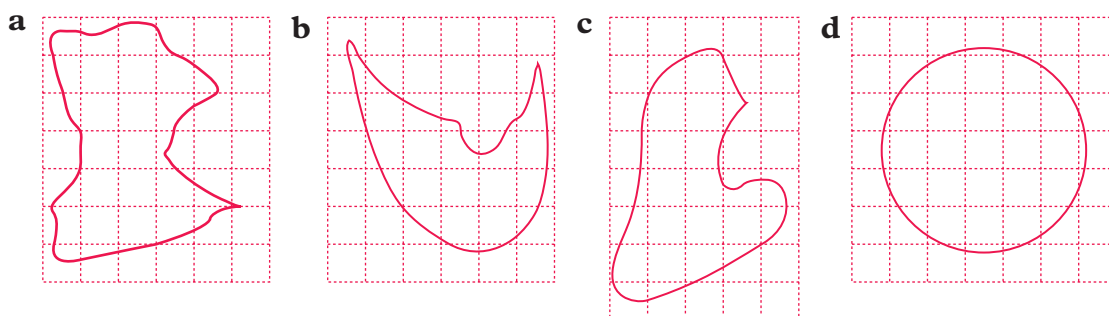

3.9.2 Areas of rectangles

You can find the area of a rectangle by counting squares. This rectangle has an area of 30 squares. If each square is 1 cm², this rectangle has an area of 30 cm².

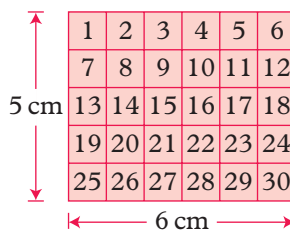

It is easier to multiply the length by the width of the rectangle than to count squares.

$$\begin{aligned} \text{Area of rectangle} &= \text{length} \times \text{width} \\ &= (6 \times 5) \text{ cm}^2 \\ &= 30 \text{ cm}^2 \end{aligned}$$

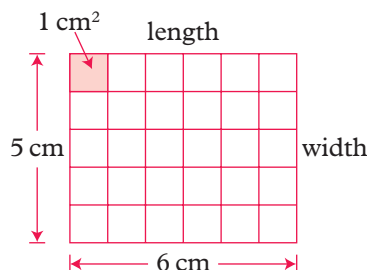

- Area of a rectangle = length \times width

A square is a special rectangle in which the length and width are equal.

- Area of a square = length \times length

Exercise 25 **L**

Calculate the areas of these rectangles. All lengths are in centimetres.

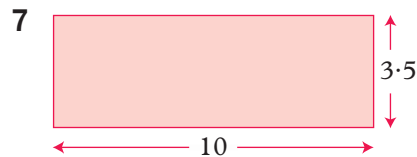
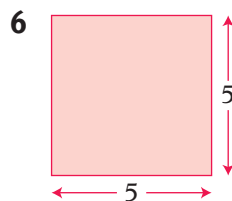
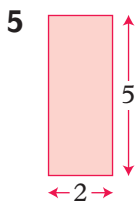
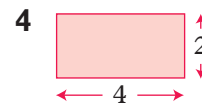
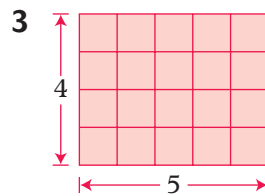
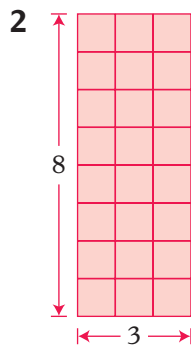
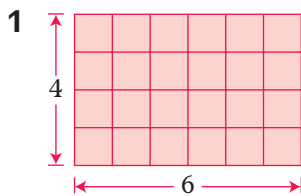

- 8 Find the area of a rectangular table measuring 60 cm by 100 cm.
- 9 A farmer's field is a square of side 200 m. Find the area of the field in m^2 .
- 10 Here is Kelly's passport photo. Measure the height and width and then work out its area in cm^2 .
- 11 Work out the area of the shaded rectangle.

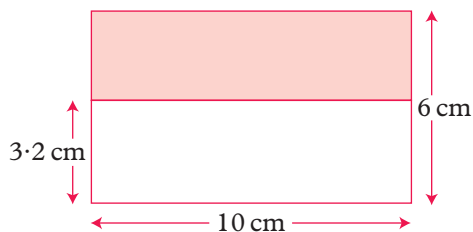

Exercise 26 M ★ F

All lengths are in cm.

- 1** This shape is made from two rectangles joined together. Find the total area of the shape.

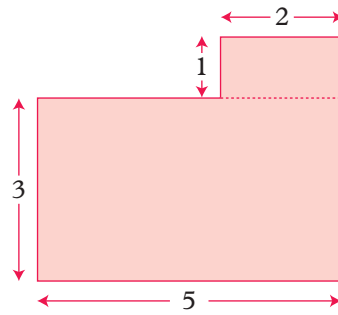

Start by finding the area of each rectangle then add them together.

The shapes in questions **2** to **12** are made of rectangles joined together. Find the area of each shape.

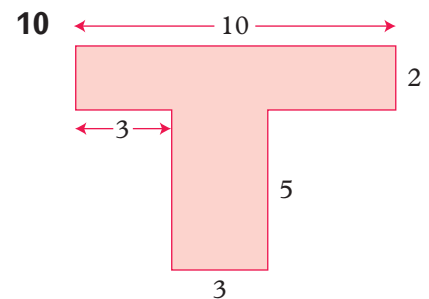
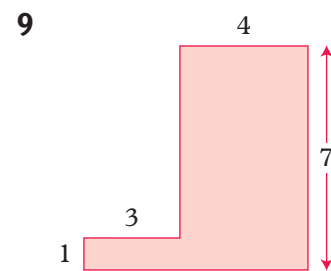
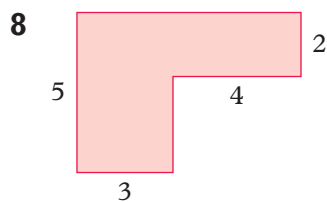
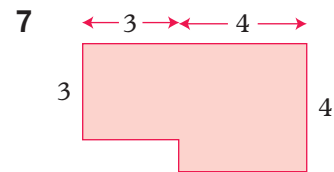
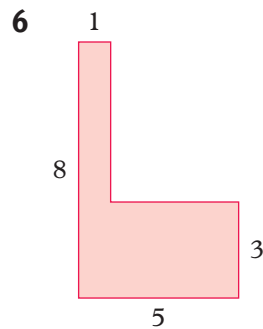
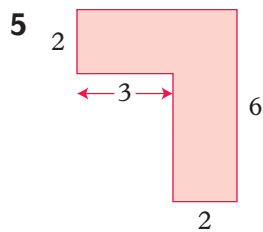
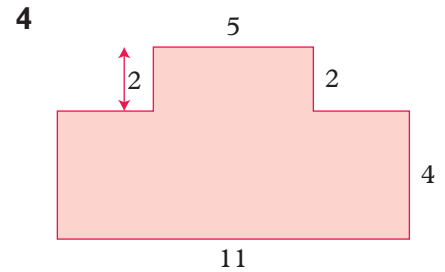
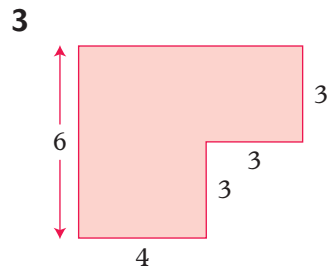
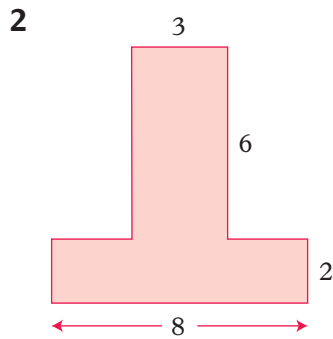

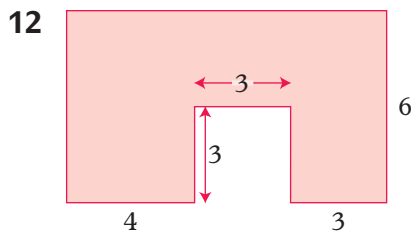
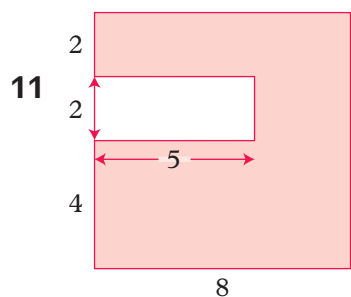

13 Here are four shapes made with centimetre squares.

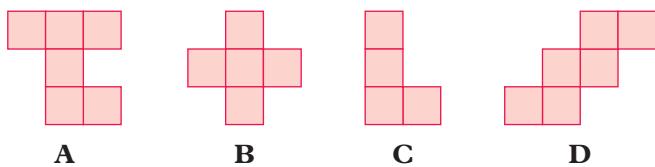

- a Which shape has an area of 5 cm^2 ?
- b Find the areas of the other three shapes.
- c Draw a shape using centimetre squares that has an area of 7 cm^2 .

? **14** A rectangular pond, measuring 10 m by 6 m, is surrounded by a path which is 1 m wide. Find the area of the path.

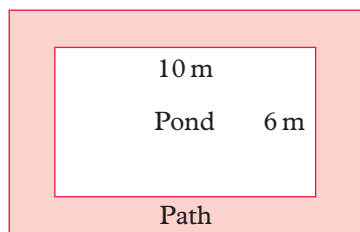

15 Find the height of each rectangle.

a

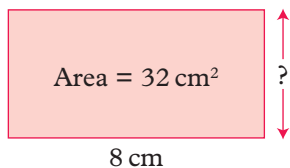

b

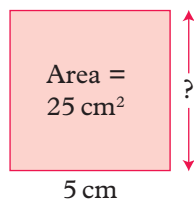

c

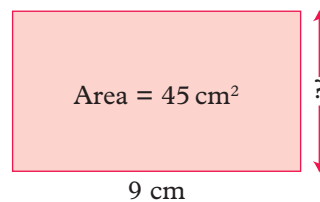

? **16** A wall measuring 3 m by 5 m is to be covered with tiles that are 20 cm squares. A box of 10 tiles costs £8.95. How much will it cost to buy the tiles for the wall?

- ?** 17 The diagram shows a garden with two crossing paths. Calculate the total area of the paths.

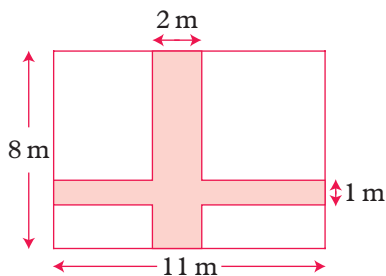

- ?** *18 A wooden cuboid has the dimensions shown. Calculate the total surface area.

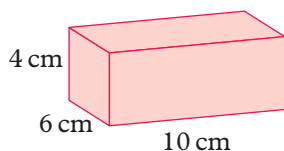

You find the surface area of a 3-D shape by adding the areas of all the faces.

3.9.3 Areas of triangles

This triangle has base 6 cm, height 4 cm and a right angle at B.

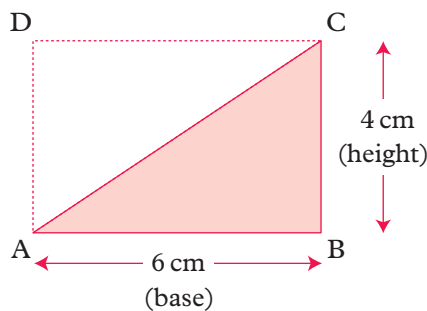

$$\begin{aligned} \text{Area of rectangle ABCD} &= (6 \times 4) \text{ cm}^2 \\ &= 24 \text{ cm}^2 \end{aligned}$$

$$\text{Area of triangle ABC} = \text{area of triangle ADC}$$

$$\begin{aligned} \text{Area of triangle ABC} &= 24 \div 2 \\ &= 12 \text{ cm}^2 \end{aligned}$$

You can show that for any triangle

$$\bullet \text{ Area} = \frac{1}{2} (\text{base} \times \text{height}) \quad \text{or} \quad \text{Area} = \frac{(\text{base} \times \text{height})}{2}$$

Learn this formula.

Exercise 27 (M)

Find the area of each triangle. Lengths are in cm.

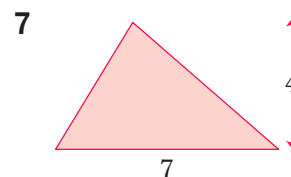
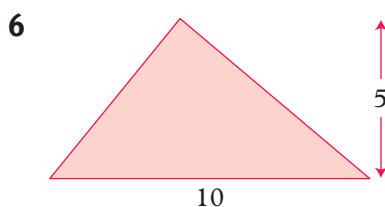
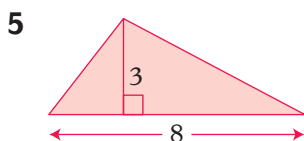
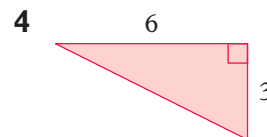
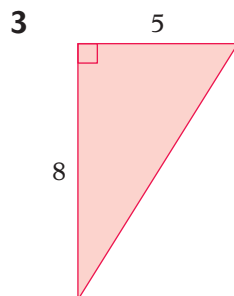
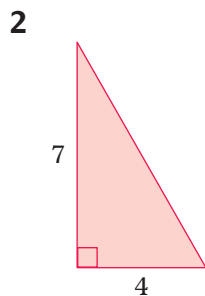
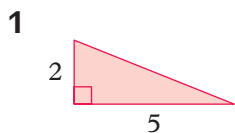

In questions 8 to 10 find the total area of each shape.

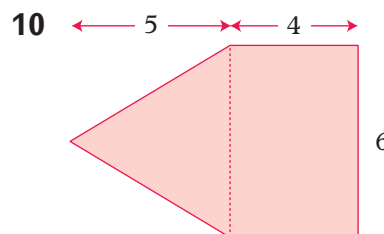
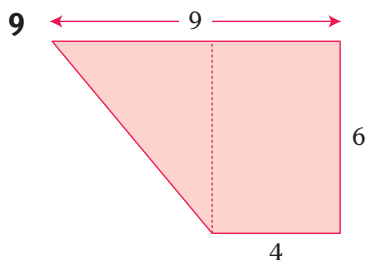
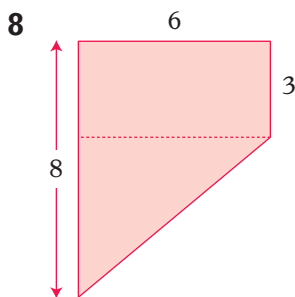

11 Find the total shaded area.

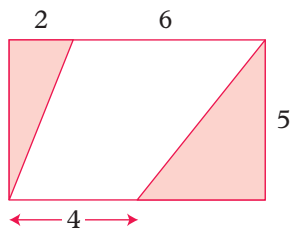

12 Find the total shaded area.

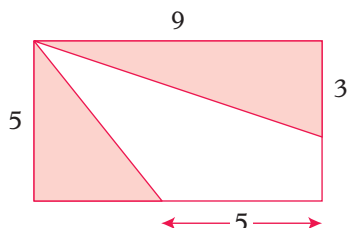

13 Find the shaded area.

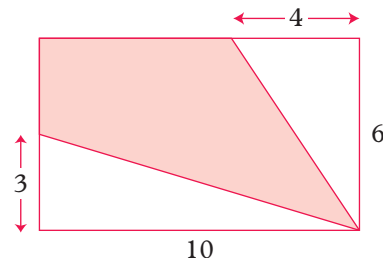

14 Find the height of each triangle.

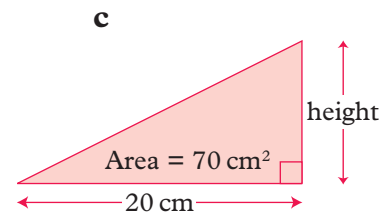
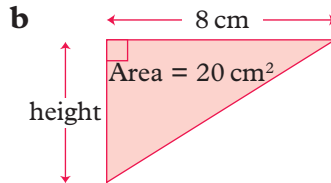
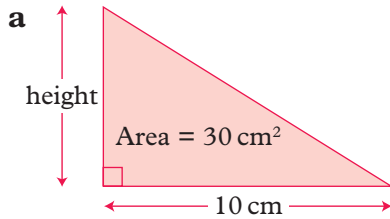

? 15 The triangle on the right has an area of 2 cm^2 .

- a** On square dotty paper draw a triangle with an area of 3 cm^2 .
b Draw a triangle, different from the one shown, with an area of 2 cm^2 .

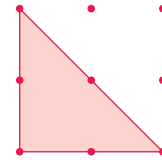

16 Joe said ‘There are 100 cm^2 in 1 m^2 .’ Mark said ‘That’s not right because one square metre is 100 cm by 100 cm so there are 10 000 cm^2 in 1 m^2 .’ Who is right?

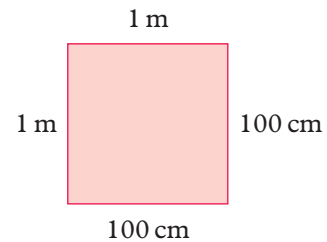

Exercise 28 **M**

- 1 a** Copy the diagram.
b Work out the areas of triangles A, B and C. Give the answer in square units.
c Work out the area of the square enclosed by the broken lines.
d Hence work out the area of the shaded triangle.

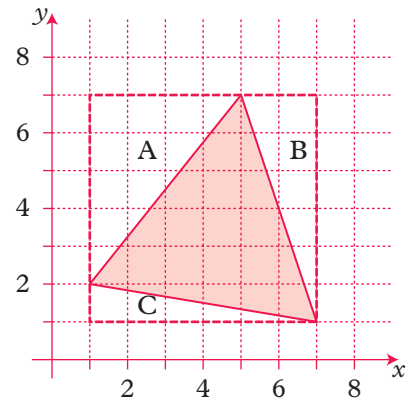

- 2 a** Copy the diagram.
b Work out the areas of triangles A, B and C.
c Work out the area of the rectangle enclosed by the broken lines.
d Hence work out the area of the shaded triangle. Give the answer in square units.

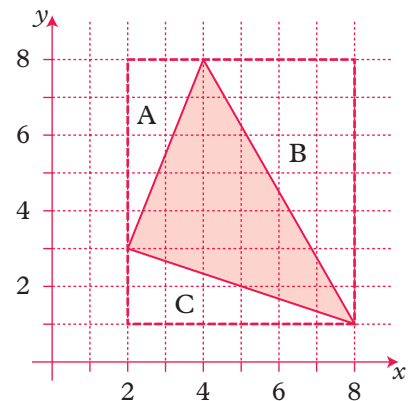

For questions 3 to 7, draw a pair of axes similar to those in questions 1 and 2. Plot the points in the order given and find the area of the shape they enclose.

3 (1, 4), (6, 8), (4, 1)

4 (1, 7), (8, 5), (4, 2)

5 (2, 4), (6, 1), (8, 7), (4, 8), (2, 4)

6 (1, 4), (5, 1), (7, 6), (4, 8), (1, 4)

7 (1, 6), (2, 2), (8, 6), (6, 8), (1, 6)

3.9.4 Areas of trapeziums and parallelograms

● Trapezium (two parallel sides) ● Parallelogram

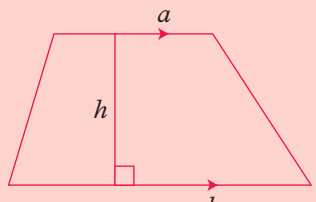

Area = $\frac{1}{2} (a + b) \times h$

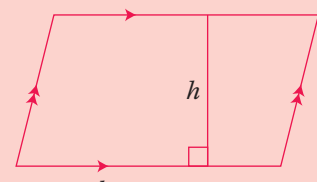

Area = $b \times h$

Exercise 29 M

Find the area of each shape. All lengths are in cm.

1

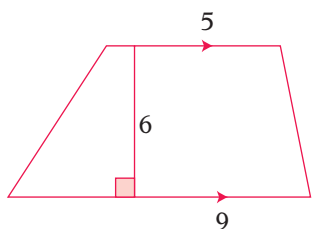

2

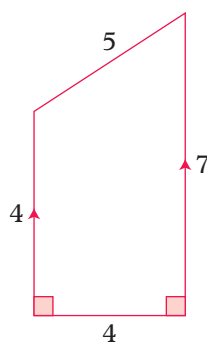

3

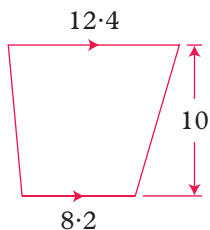

4

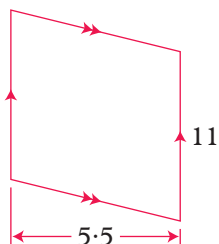

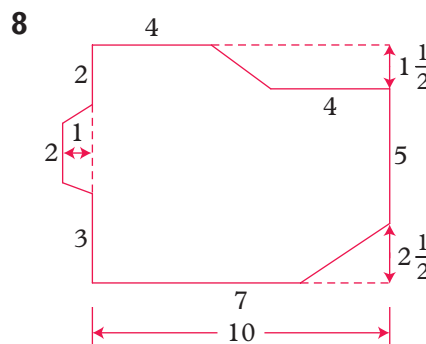
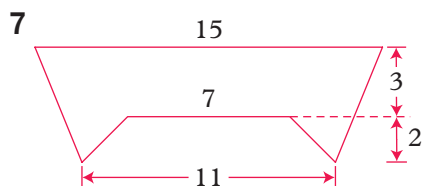
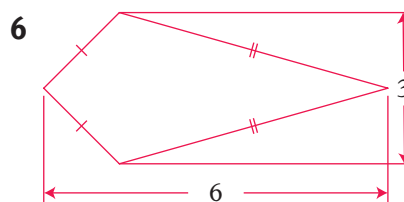
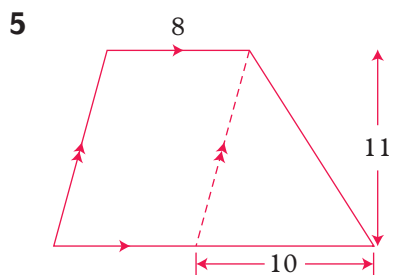

3.10 Perimeter

3.10.1 The perimeter of a shape

- The **perimeter** of a shape is the total length of its boundary.

EXAMPLE

Find the perimeters of these shapes.

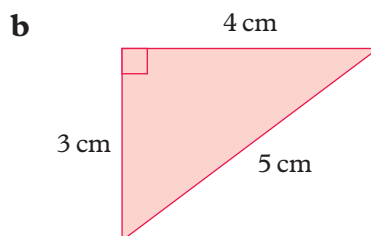
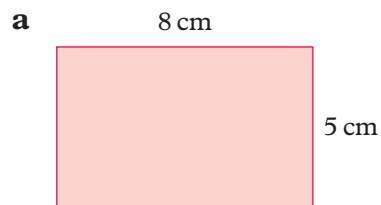

a Perimeter = $8 + 8 + 5 + 5$
 $= 26 \text{ cm}$

b Perimeter = $3 + 4 + 5$
 $= 12 \text{ cm}$

Exercise 30 (M) / (L)

1 Find the perimeter of each shape. All lengths are in cm.

a

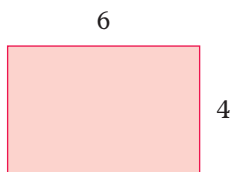

b

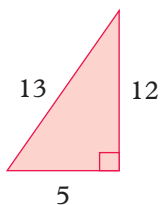

c

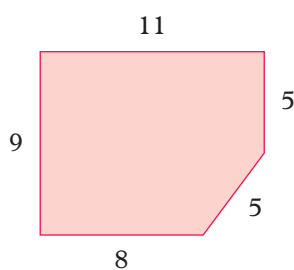

d

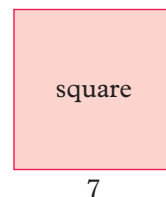

2 Measure the sides of these shapes and work out the perimeter of each one.

a

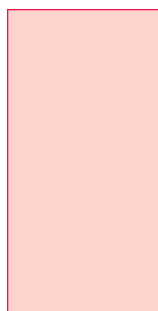

b

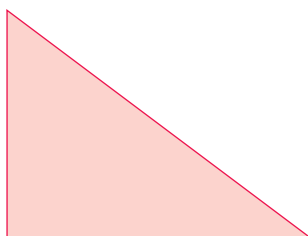

c

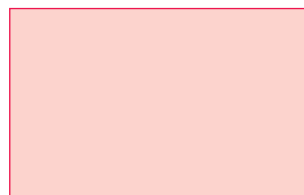

3 Here are three shapes made with centimetre squares.

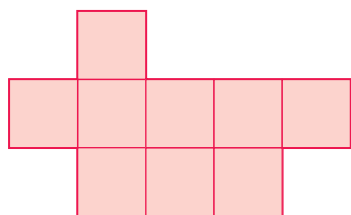

A

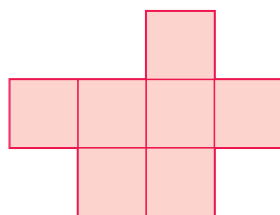

B

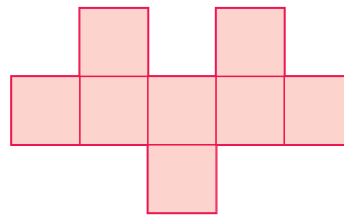

C

- a** Find the perimeter of each shape.
- b** Draw a shape of your own design with a perimeter of 14 cm.
Ask another student to check your shape.

4 Use a ruler to find the perimeter of each picture.

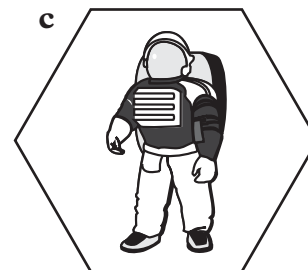
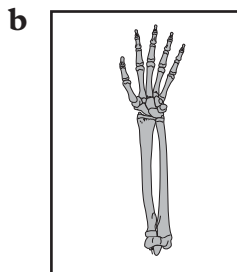
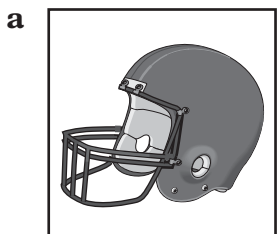

5 The perimeter of a rectangular field is 160 m. The shorter side of the field is 30 m. How long is the longer side?

6 The perimeter of a rectangular garden is 56 m. The two longer sides are each 20 m long. How long are the shorter sides of the garden?

In questions 7 to 14 find the perimeter of each shape. All lengths are in cm.

7

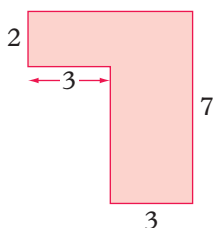

8

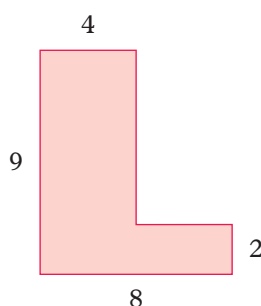

9

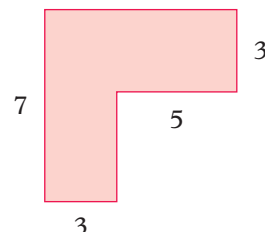

10

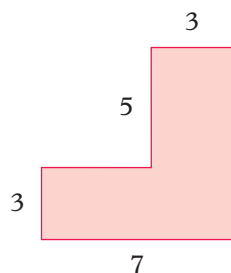

11

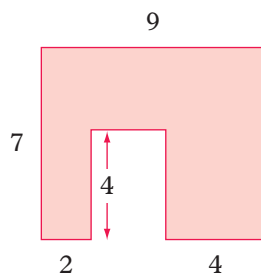

12

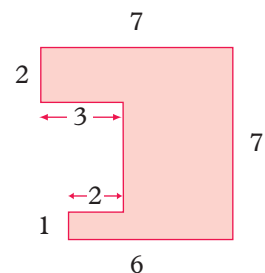

13

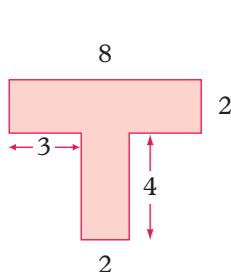

14

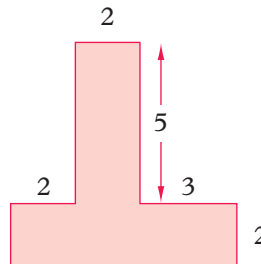

Test yourself

- 1 a A rectangle is 8 cm long and 5 cm wide.
 i Work out the area of this rectangle.
 ii Work out the perimeter of this rectangle.
- b A second rectangle has an area of 28 cm^2 .
 Write down a possible pair of values for its length and width.
- c A third rectangle is half as long and half as wide as the **rectangle in part b**.
 What is the area of the third rectangle?

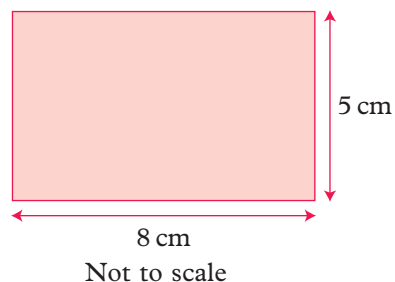

(OCR, 2009)

- 2 a Copy the diagram and draw a line from the point C perpendicular to the line AB.
- b Sketch a cylinder in your book.

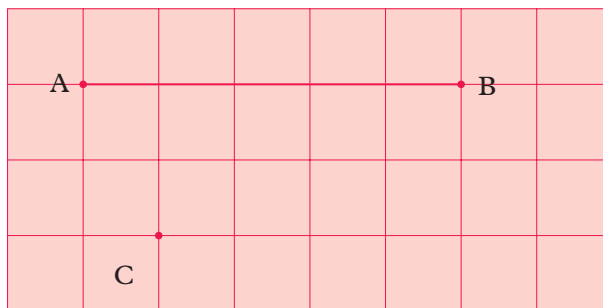

(Edexcel, 2004)

- 3 a The diagram shows three angles on a straight line AB.

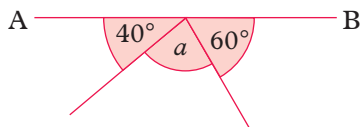

Work out the value of a .

- b Work out the values of b and c in this diagram.

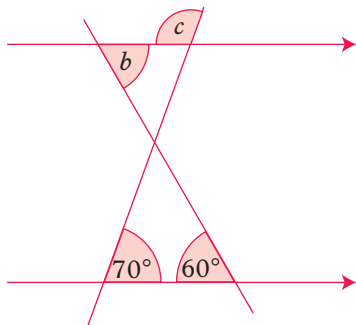

(AQA, 2004)

4 PQR is a straight line.

$PQ = QS = QR$.
 Angle $SPQ = 25^\circ$.

- a i Write down the size of angle w .
- ii Work out the size of angle x .
- b Work out the size of angle y .

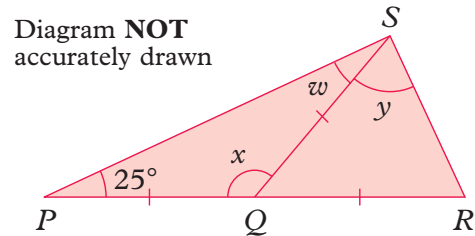

(Edexcel, 2008)

5 Here is a map of Morris Island.

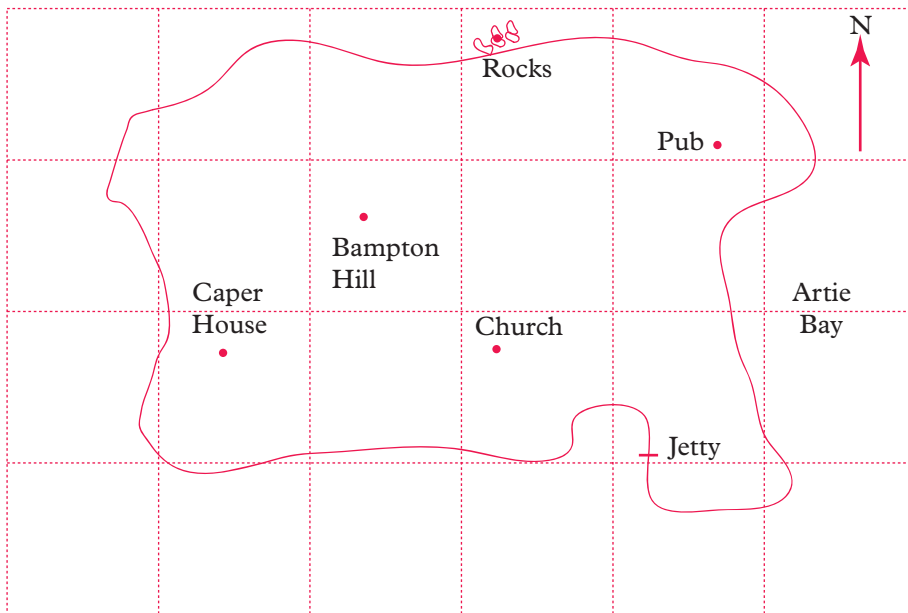

- a Roy walks from the Rocks to the Church.
 In what direction is he walking?
- b From the church he walks north-west.
 What place is he walking towards?

The side of each square on the map represents 1 km.

- c How far is it from Caper House to the Church?
- d Estimate the area of Morris island.

(OCR, 2005)

6 Here is a cuboid.

- a Write
 - i the number of edges of this cuboid,
 - ii the number of vertices of the cuboid.
- b Draw an accurate net for the cuboid.

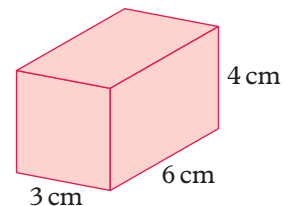

Not drawn accurately

(Edexcel, 2003)

- 7 A new country is designing its flag.
It makes the design in the shape of a triangle.
The sides of the triangle are
60 cm, 80 cm and 1 metre.

Using a scale of **1 cm to 10 cm**
construct an accurate drawing of the design.
Show your construction lines.

(OCR, 2004)

- 8 Here is a coordinate grid.

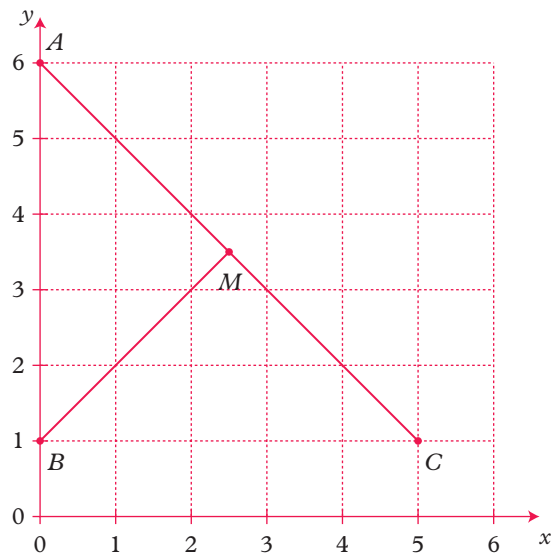

- a Write down the coordinates of the point A .
- b The line BM is extended to a point D so that the lines AC and BD are the same length.
 - i Draw the line BD on a copy of the grid.
 - ii Write down the coordinates of D .

(AQA, 2007)

- 9 The triangle ABC is shown on a centimetre grid.
- a Find the coordinates of the midpoint of BC .
 - b Find the area of the triangle ABC .
 - c Show how two triangles congruent to triangle ABC can be put together to form an isosceles triangle.

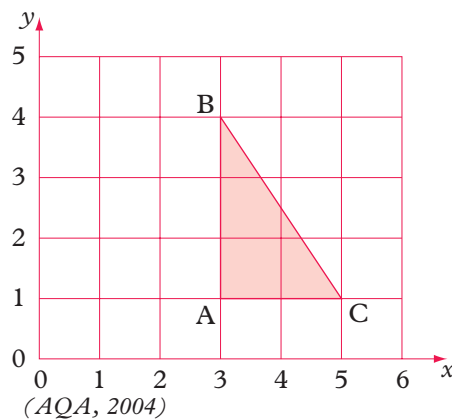

- 10** The diagram shows part of a design. Only the first quarter has been completed. The complete design must have rotational symmetry of order 4.
- Copy and complete the design by shading twelve more squares.

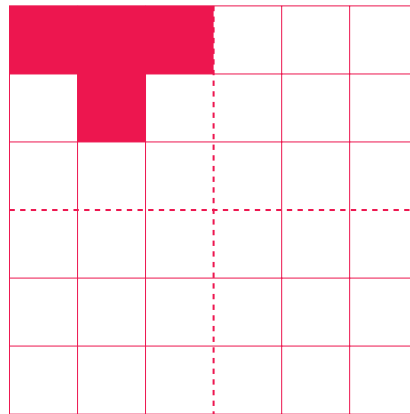

(OCR, 2004)

- 11** The length of a rectangle is 10.8 cm. The perimeter of the rectangle is 28.8 cm. Calculate the width of the rectangle.

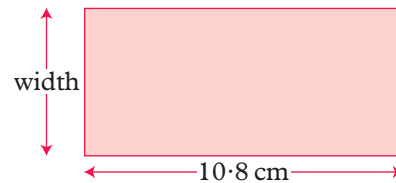

(AQA, 2004)

- 12** Look at this diagram.

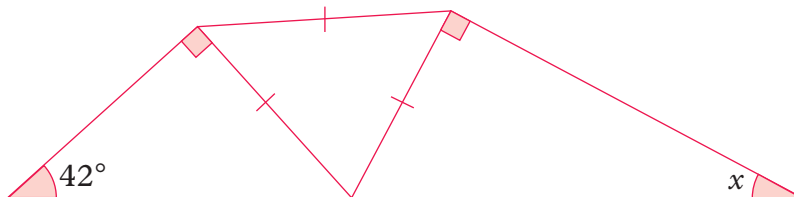

Work out the value of x .

(MEI, Spec)

- 13** The diagram shows a solid object.

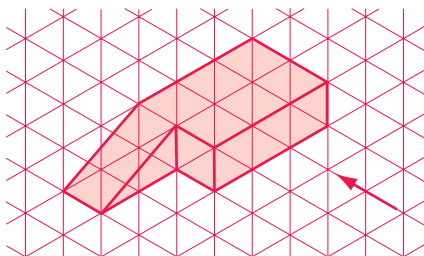

- Sketch the front elevation from the direction marked with an arrow.
- Sketch the plan of the solid object.

(Edexcel, 2004)